

Prüfbericht-Nr.: <i>Test report no.:</i>	CN23HP7N 001	Auftrags-Nr.: <i>Order no.:</i>	190150839	Seite 1 von 2 Page 1 of 2
Kunden-Referenz-Nr.: <i>Client reference no.:</i>	2542360	Auftragsdatum: <i>Order date:</i>	2023-10-11	
Auftraggeber: <i>Client:</i>	Yueqing High Quality Electric Co.,Ltd. Xiangyang Industrial Zone,Liushi, Yueqing,Zhejiang P.R. china			
Prüfgegenstand: <i>Test item:</i>	Surge Protector(Surge Protective Device)			
Bezeichnung / Typ-Nr.: <i>Identification / Type no.:</i>	HNS3-40,HNS3R-40,HNS1-40,HNS1R-40 HNS3L-40,HNS3RL-40,HNS1L-40,HNS1RL-40 (Including 1P,2P,3P,4P)			
Auftrags-Inhalt: <i>Order content:</i>	CoC LVD;UKCA			
Prüfgrundlage: <i>Test specification:</i>	EN 61643-11:2012+A11;IEC61643-11:2011; BS EN 61643-11:2012+A11			
Wareneingangsdatum: <i>Date of sample receipt:</i>	2023-10-08			
Prüfmuster-Nr.: <i>Test sample no.:</i>	Engineering sample			
Prüfzeitraum: <i>Testing period:</i>	2023-10-09 to 2023-10-26			
Ort der Prüfung: <i>Place of testing:</i>	ICTI			
Prüflaboratorium: <i>Testing laboratory:</i>	TÜV Rheinland (China) Ltd.			
Prüfergebnis*: <i>Test result*:</i>	Pass			
geprüft von: <i>tested by:</i>	genehmigt von: <i>authorized by:</i>			
Datum: <i>Date:</i> 2023-11-03	Yanru Tian/PE <i>Tian Yanru</i>		Wencai Zhang/authorizer <i>Wencai Zhang</i>	
Stellung / Position:	Sachverständige(r)/Expert	Stellung / Position:	Sachverständige(r)/Expert	
Sonstiges / Other:	<p>The report is based on CB report CN23930P 001 issued on 2023-11-02 and CB certificate HU-004632 to issue CoC LVD and UKCA.</p> <p>Appendix 1: CB report CN23930P 001; The difference between EN 61643-11:2012+A11 and IEC 61643-11:2011 is considered in appendix 2.</p> <p>Appendix 2: ATTACHMENT TO TEST REPORT IEC 61643_11 EUROPEAN GROUP DIFFERENCES AND NATIONAL DIFFERENCES (13 pages)</p> <p>BS EN 61643-11:2012+A11 is identical to EN 61643-11:2012+A11.</p>			
Zustand des Prüfgegenstandes bei Anlieferung: <i>Condition of the test item at delivery:</i>	Prüfmuster vollständig und unbeschädigt <i>Test item complete and undamaged</i>			
* Legende:	P(ass) = entspricht o.g. Prüfgrundlage(n)	F(ail) = entspricht nicht o.g. Prüfgrundlage(n)	N/A = nicht anwendbar	N/T = nicht getestet
* Legend:	P(ass) = passed a.m. test specification(s)	F(ail) = failed a.m. test specification(s)	N/A = not applicable	N/T = not tested
<p>Dieser Prüfbericht bezieht sich nur auf das o.g. Prüfmuster und darf ohne Genehmigung der Prüfstelle nicht auszugsweise vervielfältigt werden. Dieser Bericht berechtigt nicht zur Verwendung eines Prüfzeichens.</p> <p><i>This test report only relates to the above mentioned test sample. Without permission of the test center this test report is not permitted to be duplicated in extracts. This test report does not entitle to carry any test mark.</i></p>				

Prüfbericht-Nr.: Test report no.: CN23HP7N 001

Seite 2 von 2
Page 2 of 2

Anmerkungen
Remarks



1	<p>Alle eingesetzten Prüfmittel waren zum angegebenen Prüfzeitraum gemäß eines festgelegten Kalibrierungsprogramms unseres Prüfhauses kalibriert. Sie entsprechen den in den Prüfprogrammen hinterlegten Anforderungen. Die Rückverfolgbarkeit der eingesetzten Prüfmittel ist durch die Einhaltung der Regelungen unseres Managementsystems gegeben. Detaillierte Informationen bezüglich Prüfkonditionen, Prüfequipment und Messunsicherheiten sind im Prüflabor vorhanden und können auf Wunsch bereitgestellt werden.</p> <p><i>The equipment used during the specified testing period was calibrated according to our test laboratory calibration program. The equipment fulfils the requirements included in the relevant standards. The traceability of the test equipment used is ensured by compliance with the regulations of our management system. Detailed information regarding test conditions, equipment and measurement uncertainty is available in the test laboratory and could be provided on request.</i></p>
2	<p>Wie vertraglich vereinbart, wurde dieses Dokument nur digital unterzeichnet. Der TÜV Rheinland hat nicht überprüft, welche rechtlichen oder sonstigen diesbezüglichen Anforderungen für dieses Dokument gelten. Diese Überprüfung liegt in der Verantwortung des Benutzers dieses Dokuments. Auf Verlangen des Kunden kann der TÜV Rheinland die Gültigkeit der digitalen Signatur durch ein gesondertes Dokument bestätigen. Diese Anfrage ist an unseren Vertrieb zu richten. Eine Umweltgebühr für einen solchen zusätzlichen Service wird erhoben.</p> <p><i>As contractually agreed, this document has been signed digitally only. TUV Rheinland has not verified and unable to verify which legal or other pertaining requirements are applicable for this document. Such verification is within the responsibility of the user of this document. Upon request by its client, TUV Rheinland can confirm the validity of the digital signature by a separate document. Such request shall be addressed to our Sales department. An environmental fee for such additional service will be charged.</i></p>
3	<p>Prüfklausel mit der Note * wurden an qualifizierte Unterauftragnehmer vergeben und sind unter der jeweiligen Prüfklausel des Berichts beschrieben. Abweichungen von Prüfspezifikation(en) oder Kundenanforderungen sind in der jeweiligen Prüfklausel im Bericht aufgeführt.</p> <p><i>Test clauses with remark of * are subcontracted to qualified subcontractors and described under the respective test clause in the report.</i> <i>Deviations of testing specification(s) or customer requirements are listed in specific test clause in the report.</i></p>
4	<p>Die Entscheidungsregel für Konformitätserklärungen basierend auf numerischen Messergebnissen in diesem Prüfbericht basiert auf der "Null-Grenzwert-Regel" und der "Einfachen Akzeptanz" gemäß ILAC G8:2019 und IEC Guide 115:2021, es sei denn, in der auf Seite 1 dieses Berichts genannten angewandten Norm ist etwas anderes festgelegt oder vom Kunden gewünscht. Dies bedeutet, dass die Messunsicherheit nicht berücksichtigt wird und daher auch nicht im Prüfbericht angegeben wird. Zu weiteren Informationen bezüglich des Risikos durch diese Entscheidungsregel siehe ILAC G8:2019.</p> <p><i>The decision rule for statements of conformity, based on numerical measurement results, in this test report is based on the "Zero Guard Band Rule" and "Simple Acceptance" in accordance with ILAC G8:2019 and IEC Guide 115:2021, unless otherwise specified in the applied standard mentioned on Page 1 of this report or requested by the customer. This means that measurement uncertainty is not taken in account and hence also not declared in the test report. For additional information to the resulting risk based of this decision rule please refer to ILAC G8:2019.</i></p>



Test Report issued under the responsibility of:



TEST REPORT IEC 61643-11 Low-voltage surge protective devices Part 11: Surge-protective devices connected to low-voltage power systems- Requirements and test methods	
Report Number.....	CN23930P 001
Date of issue	2023-11-02
Total number of pages.....	95
Name of Testing Laboratory preparing the Report.....	Information and Communication Testing and Inspection Center of China Information Technology Design & Consulting Institute Co., Ltd.(ICTI)
Applicant's name	Yueqing High Quality Electric Co.,Ltd.
Address	Xiangyang Industrial Zone,Liushi, Yueqing,Zhejiang P.R. china
Test specification:	
Standard	IEC 61643-11:2011
Test procedure.....	CB Scheme
Non-standard test method.....	N/A
TRF template used.....	IECEE OD-2020-F1:2021, Ed.1.4
Test Report Form No.....	IEC61643_11C
Test Report Form(s) Originator	OVE
Master TRF	Dated 2021-10-07
Copyright © 2021 IEC System of Conformity Assessment Schemes for Electrotechnical Equipment and Components (IECEE System). All rights reserved. This publication may be reproduced in whole or in part for non-commercial purposes as long as the IECEE is acknowledged as copyright owner and source of the material. IECEE takes no responsibility for and will not assume liability for damages resulting from the reader's interpretation of the reproduced material due to its placement and context. If this Test Report Form is used by non-IECEE members, the IECEE/IEC logo and the reference to the CB Scheme procedure shall be removed. This report is not valid as a CB Test Report unless signed by an approved IECEE Testing Laboratory and appended to a CB Test Certificate issued by an NCB in accordance with IECEE 02.	
General disclaimer:	
This report shall not be reproduced, except in full, without the written approval of the Issuing NCB. The authenticity of this Test Report and its contents can be verified by contacting the NCB, responsible for this Test Report.	

Test item description	Surge Protector(Surge Protective Device)	
Trade Mark(s)		
Manufacturer	Wenzhou Chufeng Electric Co., Ltd	
Model/Type reference	1)HNS3-40,2)HNS3R-40, 3)HNS1-40,4)HNS1R-40, 5)HNS3L-40,6)HNS3RL-40,7)HNS1L-40,8)HNS1RL-40 (Including 1P,2P,3P,4P)	
Ratings	U _c : 1)2)3)4)385VAC(L/N to PE), 5)6)7)8)275VAC(L/N to PE); U _p : 1.8kV(L/N to PE); I _n : 20kA, I _{max} :40kA; I _{imp} : 3)4)7)8)2.25kA;Indoor; IP20 after build in; I _{SCCR} : 300A; -5°C to +40°C; 5% to 95%; Test Class:1)2)5)6)Class II, 3)4)7)8)Class I + Class II	
Responsible Testing Laboratory (as applicable), testing procedure and testing location(s):		
<input checked="" type="checkbox"/>	CB Testing Laboratory:	Information and Communication Testing and Inspection Center of China Information Technology Design & Consulting Institute Co., Ltd.(ICTI)
Testing location/ address		No.9 Dongqing street, High-tech Development Area,Zhengzhou, Henan,China
Tested by (name, function, signature)		Yang Shuo Test Engineer 
Approved by (name, function, signature) ..		Chen Qiang Authorized Signaturer 
<input type="checkbox"/>	Testing procedure: CTF Stage 1:	
Testing location/ address		
Tested by (name, function, signature)		
Approved by (name, function, signature) ..		
<input type="checkbox"/>	Testing procedure: CTF Stage 2:	
Testing location/ address		
Tested by (name + signature)		
Witnessed by (name, function, signature) ..		
Approved by (name, function, signature) ..		
<input type="checkbox"/>	Testing procedure: CTF Stage 3:	
<input type="checkbox"/>	Testing procedure: CTF Stage 4:	
Testing location/ address		
Tested by (name, function, signature)		

Witnessed by (name, function, signature) . :	
Approved by (name, function, signature) .. :	
Supervised by (name, function, signature) :	
List of Attachments (including a total number of pages in each attachment): Attachment 1: Test Equipment list (2 pages) Attachment 2: Photo Documentation(9 pages)	
Summary of testing: This report is for HNS3-40,HNS3R-40, HNS1-40,HNS1R-40,HNS3L-40,HNS3RL-40,HNS1L-40,HNS1RL-40. The test was performed on the HNS1R-40. The products is family product SPD. HNS3 series and HNS1 series are the same product, claiming a different name ,test class and Uc. The model includes R, indicating the with a microswitch, but does not include R, indicating without a microswitch. The model includes L, indicating that Uc claims 275V, and without L, indicating that Uc claims 385V. The model includes 3, indicating that the test is class II. The model includes 1, indicating that the test is class I+class II.	
Tests performed (name of test and test clause): Test sequence 1: Identification and marking 7.1.1/7.1.2/8.2 Mounting 7.3.1 Terminals and connections 7.3.2/7.3.3/8.4.2 Testing for protection against direct contact 7.2.1/8.3.1 Environment, IP code 7.4.1/8.5.1 Residual current 7.2.2/8.3.2 Operating duty test for test classes II 8.3.4.3 Additional duty test for test class I 8.3.4.4 Thermal stability 7.2.5.2/8.3.5.2 Air clearances and creepage distances 7.3.4/8.4.3 Ball pressure test 7.4.2/8.5.3 Resistance to abnormal heat and fire 7.4.3/8.5.4 Tracking resistance 7.4.4/8.5.5 Test sequence 2: Residual voltage 8.3.3.1 Test sequence 3: Insulation resistance 7.2.6/8.3.6 Dielectric withstand 7.2.7/8.3.7 Mechanical strength 7.3.5/8.4.4 Temperature withstand 7.2.5/8.3.5.1 Test sequence 4: Heat resistance 7.4.2/8.5.2 TOVs caused by faults or disturbances in the low voltage system 7.2.8.1/8.3.8.1 Test sequence 5: Short- circuit current behaviour 7.2.5.3/8.3.5.3 Additional test for SPD's failure mode simulation 7.2.5.3/8.3.5.3.2 Additional tests for SPDs with separate isolated circuits Isolation between separate circuits 7.5.3/8.3.6 /8.3.7	Testing location: Information and Communication Testing and Inspection Center of China Information Technology Design & Consulting Institute Co., Ltd.(ICTI) No.9 Dongqing street, High-tech Development Area,Zhengzhou, Henan,China

Summary of compliance with National Differences (List of countries addressed):

N/A

The product fulfils the requirements of _____ (insert standard number and edition and delete the text in parenthesis, leave it blank or delete the whole sentence, if not applicable)

Use of uncertainty of measurement for decisions on conformity (decision rule) :

No decision rule is specified by the IEC standard, when comparing the measurement result with the applicable limit according to the specification in that standard. The decisions on conformity are made without applying the measurement uncertainty ("simple acceptance" decision rule, previously known as "accuracy method").

Other:... (to be specified, for example when required by the standard or client, or if national accreditation requirements apply)

Information on uncertainty of measurement:

The uncertainties of measurement are calculated by the laboratory based on application of criteria given by OD-5014 for test equipment and application of test methods, decision sheets and operational procedures of IECEE.

IEC Guide 115 provides guidance on the application of measurement uncertainty principles and applying the decision rule when reporting test results within IECEE scheme, noting that the reporting of the measurement uncertainty for measurements is not necessary unless required by the test standard or customer.

Calculations leading to the reported values are on file with the NCB and testing laboratory that conducted the testing.

Copy of marking plate

The artwork below may be only a draft. The use of certification marks on a product must be authorized by the respective NCBs that own these marks.



Test item particulars :	
Number of ports	One port / Two port
SPD design topology	Voltage switching / Voltage limiting / Combination
SPD classified for test class	I / II / III
Location	Indoor / Outdoor
Accessibility	Accessible / Inaccessible
Mounting method	Fixed / Portable
SPD Disconnecter	Internal / External / Both
Protection functions	Thermal / Leakage current / Overcurrent
Overcurrent protection	Specified / Not specified
Degree of protection (IP code)	IP20 after build in
Temperature range	Normal / Extended
Required SPD-disconnectors	/
SPD failure behaviour:	open circuit / short circuit
Possible test case verdicts:	
- test case does not apply to the test object	N/A
- test object does meet the requirement	P (Pass)
- test object does not meet the requirement	F (Fail)
Testing :	
Date of receipt of test item	2023-10-08
Date (s) of performance of tests	2023-10-09 to 2023-10-26
General remarks:	
"(See Enclosure #)" refers to additional information appended to the report. "(See appended table)" refers to a table appended to the report.	
Throughout this report a <input type="checkbox"/> comma / <input checked="" type="checkbox"/> point is used as the decimal separator.	
Manufacturer's Declaration per Sub-clause 4.2.5 of IEC60384-14:	
The application for obtaining a CB Test Certificate includes more than one factory location and a declaration from the Manufacturer stating that the sample(s) submitted for evaluation is (are) representative of the products from each factory has been provided.....	<input type="checkbox"/> Yes <input checked="" type="checkbox"/> Not applicable
When differences exist; they shall be identified in the General product information section.	

Name and address of factory (ies) : Wenzhou Chufeng Electric Co., Ltd
No.5 Qiangheng Road, Qianheng Industrial Zone, Liushi Town, Yueqing
City,325604 Zhejiang P.R. China

General product information and other remarks:

HNS1R-40

U_C : 385VAC(L to PE, N to PE);

U_P : 1.8kV(L to PE, N to PE);

Class I: I_{imp} : 2.25kA;

Class II: I_n : 20kA, I_{max} :40kA;

Indoor; IP20 after build in; I_{SCCR} : 300A;

-5°C to +40°C; 5% to 95%;

Circuit diagrams:

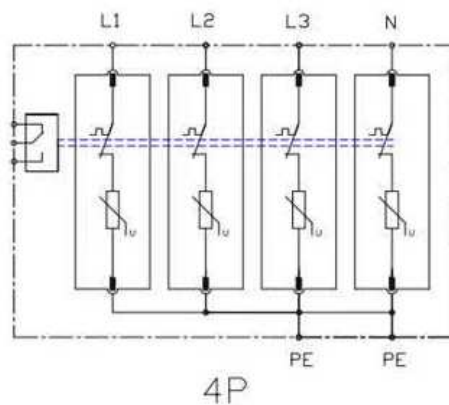

HNS3R-40/HNS1R-40/HNS1RL-40/HNS3RL-40

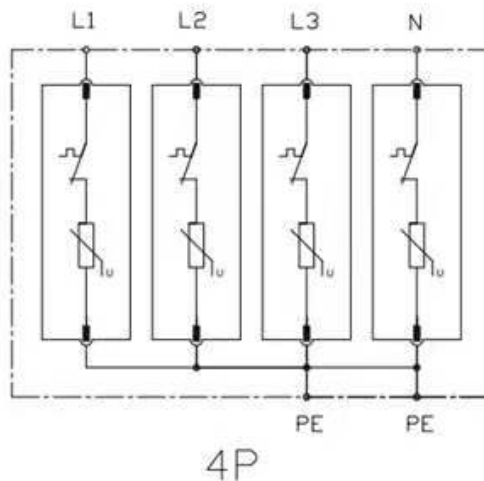

HNS3-40/HNS1-40/HNS3L-40/HNS1L-40

If not otherwise specified all tests have been carried out on three samples per test sequence.

Terminal tests have been carried out on three terminals of each construction used.

Impulse tests have been carried out according to chapters 8.1.1 to 8.1.4.

SPDs according test class I: Calculation of charge Q and specific energy W/R applied during additional duty test acc. to 8.3.4.4

I (kA)	Q (As) within 5 ms	W/R (kJ/Ω)
0,1* I _{imp} = 0.225	0.113	0.013
0,25* I _{imp} = 0.563	0.282	0.079
0,5* I _{imp} = 1.125	0.563	0.316
0,75* I _{imp} = 1.688	0.844	0.712
1,0* I _{imp} = 2.250	1.125	1.266

If the SPD is an integral part of a product covered by another standard, the requirements of the other standard were applied to those parts of the product, which do not belong to the SPD section of the product. The SPD section was judged according to the general (7.1), the electrical (7.2), the environmental and material (7.4) requirements. The mechanical requirements of other standards shall also be applied to the SPD.

Unless otherwise specified, a.c. values given in this report are r.m.s. values.

If not otherwise specified the tests have been performed in free air and at an ambient temperature of $(20 \pm 15)^\circ\text{C}$.

If not otherwise specified, for all tests where a power supply at U_{REF} or U_C is required, the voltage tolerance for testing was $^{+0}/_{-5}\%$.

If the SPD is supplied with integral cables, the full length of these cables forms part of the SPD under test, except for the determination of the measured limiting voltage 8.3.3, where a lead length of 150 mm was used.

SPD disconnectors have been selected according to the manufacturer's instructions and connected for testing according to Table 3.

For SPDs having more than one mode of protection, for which the manufacturer declares a voltage protection level, the tests have been performed on each mode, with the values chosen according to the manufacturer's declaration, using new samples each time. For three phase devices in which the protective component circuitry per given mode is identical, the testing may be performed on each of the three phases which fulfils the three sample requirement.

For SPDs with a designated N terminal which may be applied in systems without distributed neutral according to the manufacturer's instructions, separate testing has been performed for the L-PE mode of protection with the neutral being unconnected.

If the manufacturer sets different requirements for the external SPD disconnector(s) depending upon the prospective short-circuit current of the supply system, all relevant test sequences have been performed for every combination of required SPD disconnector(s) and corresponding prospective short-circuit currents.

Throughout the entire type testing procedure, the status shown by the indicator(s) give a clear sign of the status of the part to which it is linked. Where there is more than one method of status indication, for example local and remote indication, each type of indication was checked.

IEC 61643-11			
Clause	Requirement + Test	Result - Remark	Verdict

IEC 61643-11 - TEST SEQUENCE 1			
7.1.1/7.1.2	Identification and Marking		
	<u>Markings on the body or permanently attached to</u>		
	a1) Manufacturer/Trade mark/Model number	Trade mark:  Model number: HNS1R-40	P
	a2) Maximum continuous operating voltage U_c (one value for each mode of protection)	<u>385</u> VAC	P
	a3) Type of current: a.c. or “~”and/or frequency	≈	P
	a4) Test classification and discharge parameters shall be printed next to each other for each mode of protection declared by the manufacturer <u>For test class I:</u> either “test class I” and “ I_{imp} ” and the value in kA, and/or “ T1 ” (T1 in a square) and “ I_{imp} ” and the value in kA <u>For test class II:</u> either “test class II” and “ I_n ” and the value in kA, and/or “ T2 ” (T2 in a square) and “ I_n ” and the value in kA <u>For test class III:</u> either “test class III” and “ U_{oc} ” and the value in kV, and/or “ T3 ” (T3 in a square) and “ U_{oc} ” and the value in kV	<u>2.25</u> kA T1 <u>20.00</u> kA T2 _____ kV	P P N/A
	a5) Voltage protection level U_p (one value for each mode of protection)	<u>1.80</u> kV	P
	a6) Degree of protection if > IP20	IP <u>20</u> after build in	P
	a7) Identification of terminals or leads	<u>L,N,PE</u>	P
	a8) Rated load current I_L	_____	N/A
	<u>Information provided with the products</u>		
	b1) Location	<u>indoor</u>	P
	b2) Number of ports	<u>one port</u>	P
	b3) Method of mounting	<u>Fixed</u>	P

IEC 61643-11			
Clause	Requirement + Test	Result - Remark	Verdict

IEC 61643-11 - TEST SEQUENCE 1			
	b4) Short circuit current rating I_{SCCR}	<u>300A</u>	P
	b5) Ratings and characteristics for external disconnector	_____	N/A
	b6) Indication of disconnector operation	<u>internal disconnector: red is defect</u>	P
	b7) Orientation for normal installation	<u>State in user manual</u>	P
	b8) Installation instructions - type of LV systems (TN-, TT-, IT-system) - intended connection - nominal a.c. system voltages and maximum allowed voltage regulation for which the SPD is designed, mechanical dimensions, lead lengths, etc.	<u>TN system</u> <u>Refer to user manual</u>	P
	b9) Temperature and humidity range	<u>-5 °C to +40°C</u> <u>5 % to 95 %</u>	P
	b10) Follow current interrupting rating I_{fi}	_____	N/A
	b11) Residual current I_{PE}	<u>1.0mA</u>	P
	b12) Transition surge current rating for short-circuiting type SPD I_{trans}	_____	N/A
	b13) The minimum distance from any earthed conductive surface at which the SPD can be installed	_____	N/A
	b14) I_{max} (optional)	<u>40.00 kA</u>	P
	<u>Information which shall be available in a datasheet</u>		
	c1) Temporary overvoltage rating U_T and/or the type(s) of power system(s) the SPD is designed for according to Annex B and corresponding connection details	_____	N/A
	c2) Total discharge current I_{TOTAL} for multipole SPDs (if declared by the manufacturer) and the corresponding test class	_____	N/A
	c3) Voltage drop for two port SPDs	_____	N/A
	c4) Load-side surge withstand capability for two-port SPDs	_____	N/A

IEC 61643-11			
Clause	Requirement + Test	Result - Remark	Verdict

IEC 61643-11 - TEST SEQUENCE 1			
	c5) Information about replaceable parts (indicators, fuses, etc.)	_____	N/A
	c6) Voltage rate of rise du/dt	_____	N/A
	c7) Current factor k, if different from Table 20	_____	N/A
	c8) Modes of protection (for SPDs with more than one mode of protection)	<u>L to PE,N to PE</u>	P
8.2	Indelibility of markings		
	This test shall be applied on markings of all types except those made by impressing, molding and engraving.	Printed on enclosure	P
	The test is made by rubbing the marking by hand for 15s with a piece of cotton soaked with water and again for 15s with a piece of cotton soaked with aliphatic solvent hexane with a content of aromatics of maximum 0,1% volume, a kauributanol value of 29, initial boiling-point approximately 65 °C and a specific gravity of 0,68 g/cm ³ .		P
	After this test, the marking shall be easily legible.		P
7.3.1	Mounting		
	SPDs shall be provided with appropriate means for mounting that will ensure mechanical stability.	35mm standard guide rail	P
	Mechanical coding/interlock shall be provided to prevent incorrect combinations of plug-in SPD modules and sockets.		P
	Compliance is checked by visual inspection.		P
	Terminals and connections		
7.3.2	Screws, current carrying parts and connections		
8.4.1	Reliability of screws, current-carrying parts and connections		P
	Screws operated when connecting the SPD:		P

IEC 61643-11			
Clause	Requirement + Test	Result - Remark	Verdict

IEC 61643-11 - TEST SEQUENCE 1			
	<p>The screws are tightened and loosened:</p> <ul style="list-style-type: none"> - ten times for screws in engagement with a thread of insulating material - five times in all other cases 		<p>N/A</p> <p>P</p>
	Screws or nuts in engagement with a thread of insulating material are completely removed and reinserted each time unless the construction of the screw prevents this.		N/A
	The test is made by means of a suitable test screwdriver or spanner applying a torque as shown in Table 10 or according to the manufacturer's specification, whichever is greater.	<p>Screw terminals:<u>2.0</u> Nm</p> <p>Remote terminals:<u>0.4</u> Nm</p>	P
	The screws shall not be tightened in jerks.		P
	The conductor is moved each time the screw is loosened.		P
	During the test, the screwed connections shall not work loose and there shall be no damage, such as breakage of screws or damage to the head slots, threads, washers or stirrups, that will impair the further use of the SPD.		P
	Enclosures and covers shall not be damaged. This shall be verified by visual inspection.		P

IEC 61643-11			
Clause	Requirement + Test	Result - Remark	Verdict

IEC 61643-11 - TEST SEQUENCE 1			
	Terminals shall be so designed that they clamp the conductor reliably and between metal surfaces.		P
	Terminals shall be so designed or positioned that neither a rigid solid conductor nor a wire of a stranded conductor can slip out while the clamping screws or nuts are tightened.		P
7.3.3.1	Terminals with screws		
	Screws and nuts for clamping the conductors shall have a metric ISO thread or a thread comparable in pitch and mechanical strength.		P
	Terminals shall be so fixed or located that, when the clamping screws or nuts are tightened or loosened, the terminals shall not work loose from their fixings to the SPDs.		P
	These requirements do not imply that the terminals shall be so designed that their rotation or displacement is prevented, but any movement shall be sufficiently limited so as to prevent non-compliance with the requirements of this standard.		P
	The use of sealing compound or resin is considered to be sufficient for preventing a terminal from working loose, provided that: <ul style="list-style-type: none"> The sealing compound or resin is not subject to stress during normal use, and The effectiveness of the sealing compound or resin is not impaired by temperatures attained by the terminal under the least favourable conditions specified in this standard. 		P
	Clamping screws or nuts of terminals intended for the connection of protective conductors shall be adequately secured against accidental loosening.		P
	Screws shall not be made of metal that is soft or liable to creep, such as zinc or aluminium.		P
8.4.2.1.1	General		
	These tests are made by means of a suitable screwdriver or spanner applying a torque as shown in table 10.	Screw terminals: <u>5.0</u> mmØ <u>2.0</u> Nm	P
	The terminals are fitted with copper conductors of the smallest or largest cross-sectional areas specified in 8.4.2, solid or stranded, whichever is least favourable	Screw terminals: Solid: <u>4</u> to <u>35</u> mm ² Flexible: <u>4</u> to <u>25</u> mm ²	P

IEC 61643-11			
Clause	Requirement + Test	Result - Remark	Verdict

IEC 61643-11 - TEST SEQUENCE 1			
	The conductor is inserted into the terminal for the minimum distance prescribed or, where no distance is prescribed, until it just projects from the far side, and in the position most likely to assist the wire to escape		P
	The clamping screws are then tightened with a torque to two-thirds of that shown in the appropriate column of table 10.	Screw terminals: <u>1.33</u> Nm Remote terminals: <u>0.27</u> Nm	P
	Each conductor is then subjected to a pull of the value, in newtons, shown in table 12. The pull is applied without jerks, for 1 min, in the direction of the axes of the conductor space.	Screw terminals: <u>100</u> N Remote terminals: <u>50</u> N	P
	During this test, the conductor shall not move noticeably in the terminal		P
8.4.2.1.2 a)	The terminals are fitted with cooper conductors (solid or stranded), of the smallest or largest-sectional areas as specified in 8.4.2, (whichever is the least favourable) and the terminal screws are tightened with a torque equal to two-thirds of the values shown in the appropriate column of table 10. The terminal screws are then loosened and the part of the conductor which may have been affected by the terminal is inspected.	Screw terminals: Solid: min. <u>4</u> mm ² max. <u>35</u> mm ² Flexible: min. <u>4</u> mm ² max. <u>25</u> mm ²	P
	The conductors shall show neither undue damage nor severed wires		P
	Conductors are considered to be unduly damaged if they show deep or sharp indentations.		P
	During the test, terminals shall not work loose and there shall be no damage such as breakage of screws or damage to the head slots, threads, washers or stirrups, that will impair the further use of the terminal.		P
8.4.2.1.2 b)	The terminals are fitted with a rigid stranded cooper conductor according to table 13.	Screw terminals: Solid: <u>4</u> to <u>35</u> mm ² Flexible: <u>4</u> to <u>25</u> mm ²	P
	Before insertion in the terminal, the wires of the conductors are suitably reshaped		P

IEC 61643-11			
Clause	Requirement + Test	Result - Remark	Verdict

IEC 61643-11 - TEST SEQUENCE 1			
	The conductor is inserted into the terminal until the conductor reaches the bottom of the terminal or just projects from the far side of the terminal and in the position most likely to assist a wire to escape. The clamping screw or nut is then tightened with a torque equal to two-thirds of that shown in the appropriate column of table 10	Screw terminals: 5.0 mmØ 1.33 Nm	P
	After the test, no wire of the conductor shall have slipped out of the SPD terminal.		P
7.3.3.2	Screwless terminals		
	Terminals shall be so designed and constructed that: <ul style="list-style-type: none"> each conductor is clamped individually. During the connection or disconnection the conductors can be connected or disconnected either at the same time or separately, it is possible to clamp securely any number of conductors up to the maximum provided 		N/A
8.4.2.2	The terminals are fitted with new cooper conductors (solid or stranded), of the smallest or largest cross-sectional areas as specified in 8.4.2		N/A
	Each conductor is then subjected to a pull of the value shown in table 14. The pull is applied without jerks for 1 min in the direction of the axis of the conductor.	_____ to _____mm ² _____ N	N/A
8.4.2.3	Insulation piercing connections		
8.4.2.3.1	Pull test on terminals designed for single core conductors		
	The terminals are fitted with new cooper conductors (solid or stranded), of the smallest or largest cross-sectional areas as specified in 8.4.2, (whichever is the least favourable). Screws, if any, are tightened according to Table 10.	_____ mmØ _____ Nm	N/A
	The conductors are connected and disconnected five times, new conductors being used each time. After each connection the conductors are subjected to a pull, without jerks, for 1 min in the axis of the tapping conductor according to the value given in Table 14.	_____ to _____mm ² _____ N	N/A
	During the test, there shall be no movement of the conductor in the terminal or any sign of damage.		N/A

IEC 61643-11			
Clause	Requirement + Test	Result - Remark	Verdict
IEC 61643-11 - TEST SEQUENCE 1			
8.4.2.3.2	Pull test on terminals designed for multi-core cables or cords		
	The pull-out test on the SPD terminals designed for multi-core cables or cords is carried out as for single core conductors, except that the pull force is applied to the entire multi-core cable or cord instead of to the individual core.	min. _____ mm ² max. _____ mm	N/A
	The pull force is calculated according to the following formula: $F = F(x) \sqrt{n}$ F is the total force to apply n is the number of cores $F(x)$ is the force for one core according to the cross-section of one conductor (see table 9)	$F(x) = \text{_____ N}$ $n = \text{_____}$ $F = \text{_____ N}$	N/A
	During the test, the cable or cord shall not slip out of the terminals.		N/A
8.4.2.4	Flat quick connect terminations		
	Under consideration		
8.4.2.5	Pigtail connections (flying leads)		
8.4.2.5.1	Pull test on flying lead conductors		N/A
	A flying lead and anchorage shall withstand without damage or detachment a direct pull of 89N for one minute, applied to the lead from any angle which the construction or the device will allow.		N/A
	During the test, there shall be no movement of the conductor or any sign of damage.		N/A
7.2.1	Protection against direct contact		
	Test applied to SPDs with $U_c > 50V$ r.m.s.		P
	For protection against direct contact (inaccessibility of live parts), SPDs shall be so designed that, when they are wired and mounted as for normal use, live parts are not accessible, even after removal of parts which can be removed without the use of a tool.		P

IEC 61643-11			
Clause	Requirement + Test	Result - Remark	Verdict

IEC 61643-11 - TEST SEQUENCE 1			
8.3.1.1	Insulated parts		
	The sample is mounted as for normal use and the test is conducted using conductors of the smallest cross-sectional area and then again using conductors of the largest cross-sectional area specified in 8.4.2.		P
	The standard test finger (in accordance with IEC 60529) is applied in every possible position.		P
	For plug-in SPDs (which can be changed without a tool), the test finger is applied in every possible position, when the plug is partially inserted or completely inserted in a socket outlet.		P
	An electrical continuity indicator operating from a voltage of not less than 40V and not more than 50V, one side of which is connected to the test finger to check for the possibility of contact with any live part or the sample.		P
8.3.1.2	Metal parts		
	Metal parts which are accessible when the SPD is wired and mounted as for normal use are connected to earth through a low resistance connection, except of small screws and the like, isolated from live parts, for fixing bases and covers or cover plates of socket-outlets.		N/A
	A current (derived from an a.c. source having a no-load voltage not exceeding 12 V) equal to 1,5 times the rated load current or 25 A, whichever is the greater, is passed between the earthing terminal and each of the accessible metal parts in turn.	_____ A	N/A
	The voltage drop between the earthing terminal and the accessible metal part is measured and the resistance is calculated from the current and this voltage drop. The resistance shall not exceed 0,05 Ω.	_____ mV _____ Ω	N/A
7.4.1	Environment, IP code		
	SPDs shall be provided with an enclosure for protection against ingress of solid objects and water in accordance with the IP code declared by the manufacturer.		P
8.5.1	Test carried out acc. to IEC 60529 to check IP code	IP <u>20</u>	P

IEC 61643-11			
Clause	Requirement + Test	Result - Remark	Verdict

IEC 61643-11 - TEST SEQUENCE 1			
7.2.2	Residual current I_{PE}		
	For all SPDs with a terminal for the protective conductor, the residual current I_{PE} shall be measured when all SPD terminals are connected to a power supply at the reference test voltage (U_{REF}) according to the manufacturer's instructions.		P
8.3.2	The SPD shall be connected as for normal use according to the manufacturer's instructions. The voltage shall be adjusted to the reference test voltage of U_{REF} . The residual current flowing through the PE terminal is measured.	U_{REF} <u>255V</u> I_{PE} : <u>0.37mA</u>	P
7.2.4/8.3.4	Operating duty		
	The SPD shall be capable of withstanding specified discharge currents during application of the maximum continuous operating voltage U_C without unacceptable changes in its characteristics. The test setup shall comply with the circuit diagram given in Figure 7.		P
	Determination of the measured limiting voltage:	<u>1.80kV</u>	
	according to 8.3.3.1, but only at a crest value corresponding to I_{imp} for test class I	<u>2.25</u> kA / <u>1.14kV</u>	P
	according to 8.3.3.1, but only at I_n for test class II	<u>20.00kA</u> / <u>1.68kV</u>	P
	according to 8.3.3.3, but only at U_{OC} for test class III	_____ kV / _____ V	N/A
	SPDs tested acc. to class I and II containing switching components: Front-of-wave sparkover voltage acc. to 8.3.3.2 All measured peak values (5 pos./5 neg.) below U_P	_____ V	N/A
	Sample connected to power frequency source at U_C	<u>385</u> VAC	P
8.3.4.2.1	SPDs with follow current < 500A: Voltage at SPD terminals does not fall below the peak value of U_C by more than 10% during flow of follow current		P

IEC 61643-11			
Clause	Requirement + Test	Result - Remark	Verdict

IEC 61643-11 - TEST SEQUENCE 1			
8.3.4.2.2	<p>SPDs with follow current > 500A:</p> <p>Power frequency voltage U_c with a prospective short circuit current equal to the follow current interrupt rating I_n declared by the manufacturer in accordance with Table 8, or 500A, whichever is greater.</p> <p>For SPDs connected between neutral and protective earth only, the prospective short-circuit current shall be at least 100A.</p>	<p>_____ kA</p> <p>$\cos \varphi =$ _____</p>	<p>N/A</p> <p>N/A</p>
8.3.4.3	Class I and II operating duty tests		
	<p>Three groups of five impulses of 8/20 current impulses with positive polarity shall be applied. The test samples are connected to a power source according to 8.3.4.2. Each impulse shall be increased in steps of 30° with a tolerance of $\pm 5^\circ$ for each synchronisation angle.</p> <p>time interval between the impulses 50s – 60s</p> <p>time interval between the groups 30 min – 35 min</p>	<p>Class I</p> <p><u>2.25</u> kA</p> <p>Class II</p> <p><u>20.00</u> kA</p> <p>sync. 0°, 30°, 60°, 90°, 120°, 150°, 180°, 210°, 240°, 270°, 300°, 330°, 0°, 30°, 60° el.</p>	P
	<p>The SPD shall be energized at U_c. The prospective short-circuit current of the power source shall comply with 8.3.4.2 during the application of groups of impulses.</p> <p>After the application of each group of impulses and after the interruption of the last follow current (if any) the SPD shall remain energized without interruption for at least 1 min to check for reignition.</p> <p>After the last group of impulses and the 1 min period the SPD either remains applied or is reapplied within less than 30s to U_c for another 15 min to check for stability. For that purpose, the short-circuit capability of the power source (at U_c) may be reduced to 5A.</p>	<p>U_c</p> <p><u>385</u> VAC</p>	<p>P</p> <p>P</p> <p>P</p>
	When testing SPDs to class I, 8/20 current impulses with a crest corresponding to I_{imp} shall be applied.	see Annex 1	P
	When testing SPDs to class II, 8/20 current impulses with I_n shall be applied.	see Annex 1	P
	Current records show no sign of puncture or flashover of the sample		P

IEC 61643-11			
Clause	Requirement + Test	Result - Remark	Verdict

IEC 61643-11 - TEST SEQUENCE 1			
8.3.4.5	Class III operating duty tests		
	<p>The SPD is tested with three groups of impulses corresponding to U_{oc} with:</p> <ul style="list-style-type: none"> - five positive impulses initiated at crest value of positive half cycle ($\pm 5^\circ$) - five negative impulses initiated at crest value of positive half cycle ($\pm 5^\circ$) - five positive impulses initiated at crest value of positive half cycle ($\pm 5^\circ$) 	_____ kV	N/A
8.3.4.4	Additional duty test for test class I		P
	<p>This test is carried out with current impulses in steps up to I_{imp} passing through the SPD.</p> <p>SPD energized at U_c by a voltage source having a nominal current capability of 5A during the application of impulses.</p>	$U_c = \underline{385}$ VAC	P
	<p>Current impulses of positive polarity shall be initiated in the corresponding positive crest value of the power frequency voltage source to the energized test sample as follows:</p> <ul style="list-style-type: none"> a) One current impulse at $0,1 I_{imp}$ b) One current impulse at $0,25 I_{imp}$ c) One current impulse at $0,5 I_{imp}$ d) One current impulse at $0,75 I_{imp}$ e) One current impulse at $1,0 I_{imp}$ 	<p><u>0.23</u> kA</p> <p><u>0.56</u> kA</p> <p><u>1.13</u> kA</p> <p><u>1.69</u> kA</p> <p><u>2.25</u> kA</p>	P
	After each impulse cool down to ambient temperature		P
8.3.4.6	Pass criteria		
A	<p>After the application of each impulse and after interruption of each follow current (if any) the SPD shall remain energized without interruption for at least 1 min to check for re-ignition.</p> <p>After that period the SPD either remains applied or is reapplied within less than 30s to U_c for another 15 min to check for stability. For that purpose the short-circuit capability of the power source shall also be 5A.</p>		P
B	Voltage and current records and visual inspection show no sign of puncture or flashover.		P

IEC 61643-11			
Clause	Requirement + Test	Result - Remark	Verdict

IEC 61643-11 - TEST SEQUENCE 1			
C	No mechanical damage		P
D	Determination of the measured limiting voltage:	<u>1.80kV</u>	
	according to 8.3.3.1, but only at a crest value corresponding to I_{imp} for test class I	<u>2.25kA/ 1.18kV</u>	P
	according to 8.3.3.1, but only at I_n for test class II	<u>20.00kA/ 1.74kV</u>	P
	according to 8.3.3.3, but only at U_{OC} for test class III	____ kV / ____ V	N/A
	SPDs tested acc. to class I and II containing switching components: Front-of-wave sparkover voltage acc. to 8.3.3.2 All measured peak values (5 pos./5 neg.) below U_P	____ V	N/A
E	No excessive leakage currents shall occur after the test		
	If there is more than one possible connection arrangement for normal use, this check shall be performed for all arrangements		P
	The SPD shall be connected as for normal use according to the manufacturer's instructions to a power supply at the reference test voltage (U_{REF}). The current that flows through each terminal is measured. Its resistive component (measured at the crest of the sine wave)	$U_{REF} = \underline{255 V}$	P
	<ul style="list-style-type: none"> shall not exceed a value of 1 mA or	<u>0.15mA</u>	P
	<ul style="list-style-type: none"> the current shall not have changed by more than 20% compared to the initial value determined at the beginning of the test sequence 		N/A
	Any resettable or rearmable disconnecter shall be switched off and dielectric withstand shall be checked by application of two times U_C or 1000V a.c. whichever is greater.	$U_C = \text{____ V}$	N/A
	During the test, no flashover, breakdown of insulation or any other manifestation of disruptive discharge shall occur.	test voltage ____ V	N/A

IEC 61643-11			
Clause	Requirement + Test	Result - Remark	Verdict

IEC 61643-11 - TEST SEQUENCE 1			
	For SPD modes connected N-PE only, the current through the PE-terminal shall be measured, whereas the terminals are connected to a power supply at U_c . Its resistive component (measured at the crest of the sine wave) <ul style="list-style-type: none"> shall not exceed a value of 1 mA or <ul style="list-style-type: none"> the current shall not have changed by more than 20% compared to the initial value determined at the beginning of the test sequence 	$U_c = 385 \text{ V}$ $I_{PE} = 0.24 \text{ mA}$	P P N/A
F	External disconnectors shall not operate during the test and shall be in working order after the test.		N/A
G	Internal disconnectors shall not operate during the test and shall be in working order after the test.		P
M	There shall be no explosion or other hazard to either personnel or the facility.		P
7.2.5.2	Thermal protection		
	SPDs shall be protected against overheating due to degradation or overstress		P
	This test is not performed on SPDs containing only switching components and/or ABD devices.		N/A
7.2.5.4	Status indicator		
	The manufacturer shall provide information about the function of the indicator and the actions to be taken after change of status indication.		P
	A status indicator may be composed of two parts (one of which is not replaced on replacement of the SPD), linked by a coupling mechanism which can be mechanical, optical, audio, electromagnetic, etc. The part of the status indicator which is not replaced shall be capable of operating at least 50 times.		P
	Where there is an appropriate standard for the type of indication used, this shall be met by the non-replaced part of the status indicator, with the exception that the indicator need only be tested for 50 operations.		N/A

IEC 61643-11			
Clause	Requirement + Test	Result - Remark	Verdict

IEC 61643-11 - TEST SEQUENCE 1			
8.3.5.2	Thermal stability		
	If different non-linear components connected in parallel, this test has to be performed for every current path of the SPD by disconnecting/interrupting all the remaining current path. If components of the same type and parameters are connected in parallel, they shall be tested as one current path.		N/A P
	Any voltage switching component within the current path under test, which is connected in series with a voltage limiting component shall be short-circuited by a cooper dummy with a diameter such that it does not melt during the test.		N/A
	Test for SPDs containing only voltage limiting components - procedure a)		
	Sample connected to power frequency source with a voltage high enough to drive a constant current, which is increased by the following steps – 2mA or 5% of the previously adjusted test current, whichever is greater – with a tolerance of $\pm 10\%$: For sample 1#: 2 mA r.m.s. or corresponding crest value 4 mA r.m.s. or corresponding crest value 6 mA r.m.s. or corresponding crest value 8 mA r.m.s. or corresponding crest value 10 mA r.m.s. or corresponding crest value 12 mA r.m.s. or corresponding crest value For sample 2#: 4 mA r.m.s. or corresponding crest value 6 mA r.m.s. or corresponding crest value 8 mA r.m.s. or corresponding crest value 10 mA r.m.s. or corresponding crest value 12 mA r.m.s. or corresponding crest value For sample 3#: 4 mA r.m.s. or corresponding crest value 6 mA r.m.s. or corresponding crest value 8 mA r.m.s. or corresponding crest value 10 mA r.m.s. or corresponding crest value 12 mA r.m.s. or corresponding crest value	Duration 10 min 27 min 21 min 24 min 22 min 1 min 10 min 32 min 23 min 24 min 6 min 15 min 26 min 17 min 12 min 7 min	P

IEC 61643-11			
Clause	Requirement + Test	Result - Remark	Verdict

IEC 61643-11 - TEST SEQUENCE 1			
	Each step is maintained until thermal equilibrium is reached – temperature variation < 2K within 10 min		P
	Surface temperature of the hottest spot and current through the SPD are monitored continuously		P
	Test interrupted if all non-linear components under test are disconnected. The voltage is not increased further in order to avoid any malfunction of the disconnectors.		N/A
	For the other two samples the starting point shall be changed from 2 mA to a current corresponding to 5 steps below the current value at which the first sample disconnected		P
	If the voltage across the SPD falls below U_{REF} during the test, the current regulation is discontinued and the voltage is adjusted back to U_{REF} and maintained for a duration of 15 min. Continuous current monitoring is no longer required. Source short-circuit current capability does not limit the current before any disconnector operates. The maximum available current value does not exceed the short circuit withstand capability declared by the manufacturer.	$U_{REF} = \text{_____ V}$ _____ V _____ kA $\cos \phi = \text{_____}$	N/A
	Test for SPDs having a voltage switching component in series with other components – procedure b)		
	SPD energized with a power frequency source at U_{REF} having a short-circuit current capability which will not limit the current before any disconnector operates. The maximum available current value does not exceed the short-circuit withstand capability declared by the manufacturer.	_____ V _____ kA $\cos \phi = \text{_____}$	N/A
	If no significant current flows – test procedure a) shall be followed		N/A
	Pass criteria		
C	No mechanical damage		P
H	Disconnection shall be provided by one or more internal or external disconnector(s). Their correct indication shall be checked.	Internal disconnector operated	P

IEC 61643-11			
Clause	Requirement + Test	Result - Remark	Verdict

IEC 61643-11 - TEST SEQUENCE 1			
I	SPDs having an IP degree \geq IP 2X – no live parts accessible with standardised test finger applied with a force of 5N, except the ones which are accessible when the SPD is fitted as in normal use.		P
J	If disconnection occurs during the test, there shall be clear evidence of effective disconnection of the corresponding protective component(s). If internal disconnection occurs, the test sample is connected at U_c and rated frequency for 1 min. The current flow shall not exceed a value of 1 mA.	<u>385 VAC</u> <u>24.30μA</u>	P
	Currents through components connected in parallel to the relevant protective component(s), are disregarded for this measurement.		N/A
	Current through the PE-terminal shall not exceed 1mA If there is more than one possible connection arrangement for normal use, this check shall be performed for all arrangements.	<u>0.43μA</u>	P N/A
M	There shall be no explosion or other hazard to either personnel or the facility		P
O	After completion of this test the samples shall be allowed to return to room temperature and be connected to a power source at U_c for 2 hours. The residual current shall be monitored and not exceed the value measured at the beginning of the test by more than 10%.		P P
	In addition for indoor SPDs the surface temperature rise shall not exceed 120K during and after the test. 5 min. after disconnection of all non-linear components under test the surface temperature rise shall not exceed 80K.	<u>61.6 K</u> <u>40.7 K</u>	P P
7.3.4/8.4.3	Verification of air clearances and creepage distances		
	SPDs for domestic and similar applications shall be designed for pollution degree 2.		P
	SPDs for more stringent environmental applications may require special precautions, e.g. an appropriate SPD housing or an additional enclosure, which will ensure pollution degree 2 for the SPD		N/A

IEC 61643-11			
Clause	Requirement + Test	Result - Remark	Verdict

IEC 61643-11 - TEST SEQUENCE 1			
	For SPDs for outdoor and out of reach applications pollution degree 4 applies. This may be reduced to pollution degree 3 for internal distances, if they are covered by an adequate housing ensuring pollution degree 3 conditions.		N/A
	The electrode spacing of spark gaps shall not be considered for the determination of air clearances and creepage distances.		P
	The air clearances and creepage distances shall not be smaller than the values indicated in Table 15 and Table 16.		P

IEC 61643-11			
Clause	Requirement + Test	Result - Remark	Verdict

IEC 61643-11 - TEST SEQUENCE 1			
	<p>Air clearances in millimetres</p> <p>1) Between live parts of different polarity</p> <p>2) Between live parts and</p> <ul style="list-style-type: none"> – screws and other means to fasten a covering, having to be detached for mounting the SPD – fastening surfaces (note 2) – screws or other means for fastening the SPD (note 2) – bodies (notes 1 and 2) <p>3) Between the metal parts of the disconnector mechanism and</p> <ul style="list-style-type: none"> – bodies (note 1) – screws or other means for fastening the SPD <p>NOTE 1 – Definition see 8.3.6 a)</p> <p>NOTE 2 – If clearances between live parts of the device and the metallic screen or the surface on which the SPD is mounted are dependent on the design of the SPD only and cannot be reduced when the SPD is mounted in the least favourable position (even in a metallic enclosure), the values of lines 1 are sufficient.</p> <p>Creepage distances in millimetres</p> <ul style="list-style-type: none"> – r.m.s. voltage – Material group – Pollution – distances required <p>Printed wiring material</p> <ul style="list-style-type: none"> – r.m.s. voltage – Material group – Pollution – distances required 	<p>U_{max}: <u>2.18kV</u></p> <p>Valtitud:2000m required / measured</p> <p><u>3.0mm / 9.0mm</u></p> <p>____ / ____</p> <p>____ / ____</p> <p>____ / ____</p> <p><u>3.0mm / 5.3mm</u></p> <p>____ / ____</p> <p>____ / ____</p> <p><u>385V</u></p> <p><u>IIIa</u></p> <p><u>2</u></p> <p><u>4.0mm / 6.9mm</u></p> <p>____</p> <p>____</p> <p>____</p> <p>____ / ____</p>	<p>P</p> <p>N/A</p> <p>N/A</p> <p>N/A</p> <p>P</p> <p>N/A</p> <p>N/A</p> <p>P</p> <p>N/A</p>
7.4.2/8.5.3	Ball pressure test		
	Outer parts of SPDs, consist of insulating material, are submitted to a ball pressure test by means of a tester as shown on Figure 20 and 21.		P

IEC 61643-11			
Clause	Requirement + Test	Result - Remark	Verdict

IEC 61643-11 - TEST SEQUENCE 1			
	Parts of insulating material necessary to retain current carrying parts and parts of the earthing circuit in position are tested in a heating cabinet at 125°C ± 2 K.	<u>125°C</u>	P
	Parts of insulating material not necessary to retain current carrying parts and parts of the earthing circuit in position, even though they are in contact with them, are tested at 70°C ± 2 K.		N/A
	The sample to be tested is fastened accordingly, its surface being positioned horizontally; a steel ball having a diameter of 5 mm is pressed against the surface with a force of 20 N.		P
	After 1 h, the steel ball is taken away from the sample; by dipping it into cold water, the temperature of the sample is reduced to ambient temperature within 10 s.	<u>1.06 mm</u>	P
	Pass criteria		
	The diameter of the ball indentation is measured and shall not exceed 2 mm.	<u>1.06 mm</u>	P
7.4.3/8.5.4	Resistance to abnormal heat and fire		
	<p>Insulating parts of the housing shall be either non-flammable or self-extinguishing.</p> <p>The glow wire test is performed in accordance with Clauses 4 to 10 of IEC 60695-2-11 under the following conditions:</p> <ul style="list-style-type: none"> for external parts of SPDs made of insulating material necessary to retain in position current-carrying parts and parts of the protective circuit, by the test made at a temperature of 850 °C ± 15 K. for all other external parts made of insulating material, by the test made at a temperature of 650 °C ± 10 K. 	850 °C	P N/A
	The test is not made on parts of ceramic material and parts with lower size than defined in 3.1 of IEC 60695-2-11.		P
	If the insulating parts are made of the same material, the test is carried out only on one of these parts, according to the appropriate glow-wire test temperature.		P
	The test is made on one sample		P

IEC 61643-11			
Clause	Requirement + Test	Result - Remark	Verdict

IEC 61643-11 - TEST SEQUENCE 1			
	In case of doubt, the test is repeated on two additional samples.		N/A
	The test is made by applying the glow-wire once.		P
	The sample shall be positioned during the test in the least favourable position of its intended use (with the surface tested in a vertical position).		P
	The tip of the glow-wire shall be applied to the specified surface of the test sample taking into account the conditions of intended use under which a heated or glowing element may come into contact with the sample.		P
	Pass criteria		
	The sample is regarded as having passed the glow-wire test if <ul style="list-style-type: none"> • there is no visible flame and no sustained glowing or if, <ul style="list-style-type: none"> • flames and glowing parts on the sample extinguish themselves within 30 s after the removal of the glow-wire. 	Flames on the sample extinguish themselves within <u>22.7</u> s after the removal of the glow-wire.	N/A P
	There shall be no ignition of the tissue paper or scorching of the pinewood board.		P
7.4.4/8.5.5	Tracking resistance		
	The test is performed according to IEC 60112, solution A with a test voltage depending on the measured creepage distances and the required material group according to 8.3.4.	CTI <u>375V</u>	P

IEC 61643-11			
Clause	Requirement + Test	Result - Remark	Verdict

IEC 61643-11 - TEST SEQUENCE 2			
7.2.3/8.3.3	Voltage protection level		
	The measured limiting voltage of the SPDs shall not exceed the voltage protection level that is specified by the manufacturer.	<u>1.80kV</u>	P
	All one-port SPDs shall be tested unenergized.		P
	All two-port SPDs shall be tested energized for the tests according 8.3.3.1 and 8.3.3.3 by means of a voltage source having a nominal current of at least 5 A at U_c . Positive impulses are applied at the $(90 \pm 5)^\circ$ point and negative impulses at $(270 \pm 5)^\circ$ point on the sinusoidal voltage waveform.		N/A
	For a one-port SPD having terminals, the test is performed without external disconnectors and the voltage is measured at the terminals. For a one-port SPD having connecting leads the voltage is measured with external lead lengths of 150mm. For a two-port SPD, and a one-port SPD having separate load terminals, the voltage for determining the measured limiting voltage is measured at the output/load port or load terminals of the SPD and the voltage for determining U_{max} is measured at the input/line port or terminals of the SPD.	For a one-port SPD having terminals	P

IEC 61643-11			
Clause	Requirement + Test	Result - Remark	Verdict

IEC 61643-11 - TEST SEQUENCE 2			
8.3.3.1	Residual voltage with 8/20 current impulses		
	<p>Class I, 8/20 current impulses with a sequence of crest values of 0,1; 0,2; 0,5; 1,0 times the crest value of I_{imp} shall be applied.</p> <p>0,1 times I_{imp}</p> <p>0,2 times I_{imp}</p> <p>0,5 times I_{imp}</p> <p>1,0 times I_{imp}</p> <p>Class II, 8/20 current impulses with a sequence of crest values of 0,1; 0,2; 0,5; 1,0 times I_n shall be applied.</p> <p>0,1 times I_n</p> <p>0,2 times I_n</p> <p>0,5 times I_n</p> <p>1,0 times I_n</p> <p>If the SPD contains only voltage-limiting components, this test needs only to be performed at a crest values of I_{imp} for test class I or I_n for test class II.</p>	<p>_____ kA / _____ V</p> <p>_____ kA / _____ V</p> <p>_____ kA / _____ V</p> <p>_____ kA / _____ V</p> <p>_____ kA / _____ V</p> <p>_____ kA / _____ V</p> <p>_____ kA / _____ V</p> <p>_____ kA / _____ V</p> <p>Class I: <u>2.25kA/ 1.14kV</u></p> <p>Class II: <u>20.00kA/ 1.66kV</u></p>	<p>N/A</p> <p>N/A</p> <p>P</p>
	When I_{max} is declared by the manufacturer an additional 8/20 current impulse with a crest value of I_{max} shall be applied and the residual voltage shall be measured and recorded.	<u>40.00kA/2.18kV</u>	P
	One sequence of positive polarity and one sequence of negative polarity are applied to the SPD		P
	The interval between individual impulses shall be long enough for the sample to cool down to ambient temperature.		P
	Current and voltage oscillogram	see Annex 2	P
	Crest values – discharge current versus residual voltage diagram to I_n or I_{imp}	see Annex 3	P
	<p>The residual voltage used for determining the measured limiting voltage is the highest voltage value corresponding to the range of currents for:</p> <ul style="list-style-type: none"> class I: up to I_{imp} class II: up to I_n 	<p>Class I:</p> <p><u>1.14kV</u></p> <p>Class II:</p> <p><u>1.66kV</u></p>	P

IEC 61643-11			
Clause	Requirement + Test	Result - Remark	Verdict

IEC 61643-11 - TEST SEQUENCE 2			
	With these generator settings four surges will be applied to the SPD at each amplitude: two with positive and two with negative polarity.		N/A
	Current-voltage oscillograms; voltage at the output port of the SPD	see Annex 2	N/A
	The value for determining the measured limiting voltage and U_{max} is the maximum voltage recorded during the test.	_____ V	N/A
8.3.3.4	Pass criteria for all measured limiting voltage tests		
B	Voltage and current records and visual inspection show no sign of puncture or flashover.		P
C	No mechanical damage		P
I	SPDs having an IP degree \geq IP 2X – no live parts accessible with standardised test finger applied with a force of 5N, except the ones which are accessible when the SPD is fitted as in normal use.		P
M	There shall be no explosion or other hazard to either personnel or the facility		P

IEC 61643-11			
Clause	Requirement + Test	Result - Remark	Verdict

IEC 61643-11 - TEST SEQUENCE 2a			
Additional tests if declared by the manufacturer			
7.6.2.2/8.7.3	Load-side surge withstand capability		
	<p>For this test:</p> <ul style="list-style-type: none"> 15 current impulses 8/20 or, 15 combination wave impulses with an open-circuit voltage U_{oc} <p>with a value equal to the load-side surge withstand capability declared by the manufacturer are applied in three groups of five impulses to the output port of the test sample. The SPD is energized at U_c by means of a voltage source having a nominal current of at least 5 A. Each impulse shall be synchronized to the power frequency. Starting from 0° the synchronization angle shall be increased in steps of $(30 \pm 5)^\circ$.</p>	<p>_____ kA</p> <p>_____ kV</p>	N/A
	The interval between the impulses is 50 s to 60 s and the interval between the groups is 30 min to 35 min.		N/A
	The test sample shall be energized during the whole test sequence. The voltage on the output terminals shall be recorded.		N/A
	Pass criteria		
A	Thermal stability shall be achieved		N/A
B	Voltage and current records and visual inspection show no sign of puncture or flashover.		N/A
C	No mechanical damage		N/A
D	Determination of the measured limiting voltage:	$U_P \leq$ _____ V	
	according to 8.3.3.1, but only at a crest value corresponding to I_{limp} for test class I	_____ kA / _____ V	N/A
	according to 8.3.3.1, but only at I_n for test class II	_____ kA / _____ V	N/A
	according to 8.3.3.3, but only at U_{oc} for test class III	_____ kA / _____ V	N/A
	<p>SPDs tested acc. to class I and II containing switching components:</p> <p>Front-of-wave sparkover voltage acc. to 8.3.3.2</p> <p>All measured peak values (5 pos./5 neg.) below U_P</p>	_____ kV	N/A
E	No excessive leakage currents shall occur after the test		

IEC 61643-11			
Clause	Requirement + Test	Result - Remark	Verdict

IEC 61643-11 - TEST SEQUENCE 2a			
Additional tests if declared by the manufacturer			
	If there is more than one possible connection arrangement for normal use, this check shall be performed for all arrangements		N/A
	The SPD shall be connected as for normal use according to the manufacturer's instructions to a power supply at the reference test voltage (U_{REF}). The current that flows through each terminal is measured. Its resistive component (measured at the crest of the sine wave) <ul style="list-style-type: none"> shall not exceed a value of 1 mA or <ul style="list-style-type: none"> the current shall not have changed by more than 20% compared to the initial value determined at the beginning of the test sequence 	$U_{REF} = \text{_____ V}$	N/A N/A N/A
	Any resettable or rearmable disconnecter shall be switched off and dielectric withstand shall be checked by application of two times U_c or 1000V a.c. whichever is greater. During the test, no flashover, breakdown of insulation or any other manifestation of disruptive discharge shall occur.	$U_c = \text{_____ V}$ test voltage _____ V	N/A N/A
	For SPD modes connected N-PE only, the current through the PE-terminal shall be measured, whereas the terminals are connected to a power supply at U_c . Its resistive component (measured at the crest of the sine wave) <ul style="list-style-type: none"> shall not exceed a value of 1 mA or <ul style="list-style-type: none"> the current shall not have changed by more than 20% compared to the initial value determined at the beginning of the test sequence 	$U_c = \text{_____ V}$ $I_{PE} = \text{_____ mA}$	N/A N/A N/A
F	External disconnectors shall not operate during the test and shall be in working order after the test.		N/A
G	Internal disconnectors shall not operate during the test and shall be in working order after the test.		N/A

IEC 61643-11			
Clause	Requirement + Test	Result - Remark	Verdict

IEC 61643-11 - TEST SEQUENCE 2b Additional tests for two-port SPDs and one port-SPDs with separate input / output terminals			
7.5.1.3	Load-side short-circuit current behaviour		
	The SPD shall be able to carry the currents caused by a power short-circuit on the load side until it is interrupted either by the SPD itself or by an internal or external disconnecter.		
8.6.1.3	This test applies to all SPDs, except those classified for outdoor use and mounted out of reach and those connected N-PE for use in TN and/or TT systems only.		N/A
	<p>The test settings and the test procedure according to 8.3.5.3 (excluding 8.3.5.3.1) are repeated without short-circuiting any components, but with a short-circuit link connected to the following output terminals of the SPD as applicable:</p> <ul style="list-style-type: none"> • short-circuit link across all phase terminals and the neutral terminal (if applicable) on the load side • short-circuit link across all terminals on the load side, <p>with a conductors of the largest cross-section specified under 8.4.2 and with a length of 500 mm each.</p>		N/A N/A N/A
	Pass criteria		
C	No mechanical damage		N/A
E	No excessive leakage currents shall occur after the test		
	If there is more than one possible connection arrangement for normal use, this check shall be performed for all arrangements		N/A
	<p>The SPD shall be connected as for normal use according to the manufacturer's instructions to a power supply at the reference test voltage (U_{REF}).</p> <p>The current that flows through each terminal is measured. Its resistive component (measured at the crest of the sine wave)</p> <ul style="list-style-type: none"> • shall not exceed a value of 1 mA <p>or</p> <ul style="list-style-type: none"> • the current shall not have changed by more than 20% compared to the initial value determined at the beginning of the test sequence 	$U_{REF} = \underline{\hspace{1cm}} \text{ V}$ $\underline{\hspace{1cm}} \text{ mA}$	N/A N/A N/A

IEC 61643-11			
Clause	Requirement + Test	Result - Remark	Verdict

IEC 61643-11 - TEST SEQUENCE 2b Additional tests for two-port SPDs and one port-SPDs with separate input / output terminals			
	<p>Any resettable or rearmable disconnecter shall be switched off and dielectric withstand shall be checked by application of two times U_c or 1000V a.c. whichever is greater.</p> <p>During the test, no flashover, breakdown of insulation or any other manifestation of disruptive discharge shall occur.</p>	$U_c = \text{_____ V}$ test voltage _____ V	N/A N/A
	<p>For SPD modes connected N-PE only, the current through the PE-terminal shall be measured, whereas the terminals are connected to a power supply at U_c.</p> <p>Its resistive component (measured at the crest of the sine wave)</p> <ul style="list-style-type: none"> shall not exceed a value of 1 mA <p>or</p> <ul style="list-style-type: none"> the current shall not have changed by more than 20% compared to the initial value determined at the beginning of the test sequence 	$U_c = \text{_____ V}$ $I_{PE} = \text{_____ } \mu\text{A}$	N/A N/A N/A
H	Disconnection shall be provided by one or more internal or external disconnecter(s). Their correct indication shall be checked.		N/A
I	SPDs having an IP degree \geq IP 2X – no live parts accessible with standardised test finger applied with a force of 5N, except the ones which are accessible when the SPD is fitted as in normal use.		N/A
J	<p>If disconnection occurs during the test, there shall be clear evidence of effective disconnection of the corresponding protective component(s).</p> <p>If internal disconnection occurs, the test sample is connected at U_c and rated frequency for 1 min.</p> <p>The current flow shall not exceed a value of 1 mA.</p>	_____ V _____ mA	N/A
	Currents through components connected in parallel to the relevant protective component(s), are disregarded for this measurement.		N/A
	<p>Current through the PE-terminal shall not exceed 1mA</p> <p>If there is more than one possible connection arrangement for normal use, this check shall be performed for all arrangements.</p>	_____ mA	N/A N/A

IEC 61643-11			
Clause	Requirement + Test	Result - Remark	Verdict

IEC 61643-11 - TEST SEQUENCE 2b Additional tests for two-port SPDs and one port-SPDs with separate input / output terminals			
K	The short-circuit current from the power source, if any, shall be interrupted within 5 s by one or more internal and/or external disconnecter(s).		N/A
M	There shall be no explosion or other hazard to either personnel or the facility.		N/A
N	There shall be no flashover to the metallic screen and the 6 A gL/gG fuse connecting the screen shall not operate during the test.		N/A
	a) Internal disconnecter(s) have operated:		
	After removing the short-circuit links from output terminals and with U_{REF} applied according to the circuit shown in Figure 22, there shall be no voltage on the output terminals.		N/A
	With a power frequency voltage equal to two times U_c applied between all corresponding input and output phase terminals for 1 min there shall be no current flow in excess of 0,5 mA.		N/A
	a) No internal disconnecter has operated:		
D	Determination of the measured limiting voltage:	$U_P \leq \text{_____ V}$	N/A
	according to 8.3.3.1, but only at a crest value corresponding to I_{imp} for test class I	_____ kA / _____ V	N/A
	according to 8.3.3.1, but only at I_n for test class II	_____ kA / _____ V	N/A
	according to 8.3.3.3, but only at U_{oc} for test class III	_____ kV / _____ V	N/A
	SPDs tested acc. to class I and II containing switching components: Front-of-wave sparkover voltage acc. to 8.3.3.2 All measured peak values (5 pos./5 neg.) below U_P	_____ kV	N/A

IEC 61643-11			
Clause	Requirement + Test	Result - Remark	Verdict

IEC 61643-11 - TEST SEQUENCE 3			
7.2.6/8.3.6	Insulation resistance		
	The insulation resistance of the SPD shall be sufficient with respect to leakage currents and protection against direct contact. This test is not applicable to SPDs having a metallic enclosure connected to protective earth.		P
	Additional entry holes for cables, if there are any, are left open. If there are any knockouts, one of them is opened. Coverings and other parts which are detachable without tools, are removed and undergo the same moisture treatment.		P
	The moisture treatment is carried out in a humidity cabinet at a relative humidity of 93% \pm 3% RH. The air temperature is kept at all points, where the test sample can be positioned, within \pm 2 K at a suitable temperature T between 20°C and 30°C. Before putting the test samples into the humidity cabinet, they shall have a temperature between T and (T+4) in °C.	+24°C, 93% RH for 48 h	P
	The samples shall be kept in the humidity cabinet for 2 days (48 h).		P
	After a delay of between 30 min and 60 min following the humidity treatment, the insulation resistance is measured 60 s after having applied a d.c. voltage of 500 V.		P

IEC 61643-11			
Clause	Requirement + Test	Result - Remark	Verdict

IEC 61643-11 - TEST SEQUENCE 3			
	<p>This measurement is carried out in the humidity cabinet or in the room into which the specimens were brought to reach the determined temperature, after having refitted the parts which might have been detached.</p> <p>a) between all interconnected live parts and the SPDs body accessible to accidental contact.</p> <p>The express "body" in the sense of this test means</p> <ul style="list-style-type: none"> • all touchable metal parts and a metal foil on surfaces of insulating material, which are touchable after installation as for normal use, • the surface on which the SPD is mounted, if necessary covered with metal foil, • screws and other facilities for fastening the SPD on its support <p>Fore these measurements, the metal foil is put on in such a way, that perhaps existing casting mass is effectively tested.</p> <p>Protective components connected to PE may be disconnected for this test</p> <p>b) between the live parts of the SPD main circuit and live parts of separate isolated circuits, if there are any.</p>	<p>a)Between enclosure and live parts</p> <p>b)Between the live parts and live parts of remote terminal</p>	<p>P</p> <p>P</p>
	Pass criteria		
	<p>The insulation resistance shall not be lower than</p> <ul style="list-style-type: none"> • 5 MΩ for the measurements according to a), • 2 MΩ for the measurements according to b). 	<p>≥2000 MΩ</p> <p>≥2000 MΩ</p>	<p>P</p> <p>P</p>
7.2.7/8.3.7	Dielectric withstand		
	The dielectric withstand of the SPD shall be sufficient with respect to insulation breakdown and protection against direct contact.		
	SPDs classified for outdoor use are tested between the terminals with the internal parts removed. During this test, the SPD is subjected to sprinkling according to 9.1 of IEC 60060-1.		N/A
	SPDs classified for indoor are tested as indicated in a) and b) of 8.3.6.		P

IEC 61643-11			
Clause	Requirement + Test	Result - Remark	Verdict

IEC 61643-11 - TEST SEQUENCE 3			
	<p>SPDs are tested with an a.c. voltage according to Table 9. Starting with not more than half the required a.c. voltage, this voltage is increased to the full value within 30 s which is maintained for 1 min.</p> <p>a) between all interconnected live parts and the SPDs body accessible to accidental contact.</p> <p>b) The express "body" in the sense of this test means</p> <ul style="list-style-type: none"> • all touchable metal parts and a metal foil on surfaces of insulating material, which are touchable after installation as for normal use, • the surface on which the SPD is mounted, if necessary covered with metal foil, • screws and other facilities for fastening the SPD on its support <p>Fore these measurements, the metal foil is put on in such a way, that perhaps existing casting mass is effectively tested.</p> <p>Protective components connected to PE may be disconnected for this test.</p> <p>c) between the live parts of the SPD main circuit and live parts of separate isolated circuits, if there are any.</p>	<p>a) Between enclosure and live parts, the AC test voltage(rms): 2.2kV for 1min</p> <p>b)Between the live parts and live parts of remote terminal, the AC test voltage(rms): 2.2kV for 1min</p>	<p>P</p> <p>P</p>
	Pass criteria		
	Arcing or puncturing shall not occur, however, partial discharges are accepted if the voltage change the discharge is less than 5%.		P
	The power transformer used for testing shall be designed in such a way that after having been adjusted to the test voltage at its open terminals it will generate a short-circuit current of at least 200 mA after short-circuiting the terminals. An overcurrent relay, if any, shall only react if the test circuit current exceeds 100 mA. The device for measuring the test voltage shall have a precision of $\pm 3\%$.		P
7.3.5/8.4.4	Mechanical strength		
	All parts of the SPD relating to the protection against direct contact shall have sufficient mechanical strength.		
	The samples are subjected to strikes by means of an impact-test apparatus as shown in Figure 18 and Figure 19.		P

IEC 61643-11			
Clause	Requirement + Test	Result - Remark	Verdict

IEC 61643-11 - TEST SEQUENCE 3			
	Samples are mounted on a sheet of plywood, 8 mm thick and 175 mm square, secured at its top and bottom edges to a ridged bracket.		P
	Portable SPDs are tested as fixed SPDs, but they are fixed to the plywood sheet by auxiliary means.		N/A
	Flush-type SPDs are mounted in a recess provided in a block of hornbeam or material having similar mechanical characteristics, which is fixed to a sheet of plywood. (They are not tested in their relevant mounting boxes.)		N/A
	If wood is used for the block, the direction of the wood fibres shall be perpendicular to the direction of the impact.		P
	Flush-type screw fixing SPDs shall be fixed by means of screws to lugs recessed in the block.		N/A
	Flush-type claw fixing SPDs shall be fixed to the block by means of the claws.		N/A
	Before applying the strikes, fixing screw of bases and covers are tightened with a torque equal to two-thirds of that specified in Table 10.	_____ Nm	N/A

IEC 61643-11			
Clause	Requirement + Test	Result - Remark	Verdict

IEC 61643-11 - TEST SEQUENCE 3															
	<p>The samples are mounted so that the point of impact lies in the vertical plane through the axis of the pivot.</p> <p>The striking element is allowed to fall from a height which is specified in the following Table 18:</p> <table border="0"> <tr> <td>parts A and B</td> <td>h = 100 mm</td> <td><u>100mm</u></td> <td>P</td> </tr> <tr> <td>parts C</td> <td>h = 150 mm</td> <td>—</td> <td>N/A</td> </tr> <tr> <td>parts D</td> <td>h = 200 mm</td> <td><u>200mm</u></td> <td>P</td> </tr> </table> <p>A: parts on the front surface, including parts which are recessed.</p> <p>B: Parts which do not project more than 15 mm from the mounting surface (distance from the wall) after mounting as in normal use, with the exception of the above parts A.</p> <p>C: Parts which project more than 15 mm and not more than 25 mm from the mounting surface (distance from the wall) after mounting as in normal use, with the exception of the above parts A.</p> <p>D: Parts which project more than 25 mm from the mounting surface (distance from the wall) after mounting as in normal use, with the exception of the above parts A.</p>	parts A and B	h = 100 mm	<u>100mm</u>	P	parts C	h = 150 mm	—	N/A	parts D	h = 200 mm	<u>200mm</u>	P		
parts A and B	h = 100 mm	<u>100mm</u>	P												
parts C	h = 150 mm	—	N/A												
parts D	h = 200 mm	<u>200mm</u>	P												
	The heights of the fall determined by the part of the sample which projects most from the mounting surface is applied on all parts of the sample, with the exception of parts A		P												
	The samples are subjected to strikes which are evenly distributed over the samples. The strikes are not applied to "knock-out" areas.		P												

IEC 61643-11			
Clause	Requirement + Test	Result - Remark	Verdict
IEC 61643-11 - TEST SEQUENCE 3			
	<p>The following blows are applied:</p> <ul style="list-style-type: none"> • for parts A, five strikes: one in the centre. After the sample has been moved horizontally: one each on the unfavourable points between the centre and the edges; and then, after the sample has been turned 90° about its axis perpendicular to the plywood, one each on similar points; • for parts B (as far as applicable), C and D, four blows: <ul style="list-style-type: none"> – one on one side of the sample of the sample after the plywood sheet has been turned 60° and one blow on another side of the sample after it has been turned 90° about its axis perpendicular to the plywood sheet, keeping the position of the plywood sheet unchanged; – one blow on each of the other two sides of the sample, with the plywood sheet turned 60° in the opposite direction. 		P
			P
			P
	Pass criteria		
	After the test, the sample shows no damage within the meaning of the standard. In particular, live parts have not become accessible with the standard test finger.		P
	Damage to the finish small dents which do not reduce creepage distances or clearances and small chips which do not adversely affect the protection against electric shock or harmful ingress of water are neglected		N/A
	Cracks not visible with the normal or corrected vision, without additional magnification, and surface cracks in fibre reinforced mouldings and the like are ignored.		N/A
7.2.5/8.3.5.1	Temperature withstand		
	The SPD is kept in a heated cabinet at an ambient temperature of 80 °C ± 5 K for 24 h.	<u>80</u> °C for 24 h	P
	Pass criteria		
C	No mechanical damage		P
G	Internal disconnectors shall not operate during the test and shall be in working order after the test.		P
Remarks:			

IEC 61643-11			
Clause	Requirement + Test	Result - Remark	Verdict

IEC 61643-11 - TEST SEQUENCE 3a			
<i>Additional tests for SPDs with separate isolated circuits</i>			
7.5.3	Where a SPD includes a circuit that is electrically isolated from the main circuit, the manufacturer shall provide information about the isolation and dielectric withstand voltages between the circuits as well as the relevant standards that the manufacturer is claiming conformity with.		P
	Where there are more than two circuits, declarations shall be made with regard to each combination of circuits.	_____	N/A
8.3.6	Insulation resistance		
	The moisture treatment is carried out in a humidity cabinet at a relative humidity of 93% ± 3% RH. The air temperature is kept at all points, where the test sample can be positioned, within ± 2 K at a suitable temperature T between 20°C and 30°C. Before putting the test samples into the humidity cabinet, they shall have a temperature between T and (T+4) in °C.	+24°C, 93% RH for 48 h	P
	The samples shall be kept in the humidity cabinet for 2 days (48 h).		P
	After a delay of between 30 min and 60 min following the humidity treatment, the insulation resistance is measured 60 s after having applied a d.c. voltage of 500 V.		P

IEC 61643-11			
Clause	Requirement + Test	Result - Remark	Verdict

IEC 61643-11 - TEST SEQUENCE 3a			
Additional tests for SPDs with separate isolated circuits			
	<p>This measurement is carried out in the humidity cabinet or in the room into which the specimens were brought to reach the determined temperature, after having refitted the parts which might have been detached.</p> <p>a) between all interconnected live parts of the separate circuits and the SPDs body accessible to accidental contact.</p> <p>The express "body" in the sense of this test means</p> <ul style="list-style-type: none"> • all touchable metal parts and a metal foil on surfaces of insulating material, which are touchable after installation as for normal use, • the surface on which the SPD is mounted, if necessary covered with metal foil, • screws and other facilities for fastening the SPD on its support <p>Fore these measurements, the metal foil is put on in such a way, that perhaps existing casting mass is effectively tested.</p> <p>Protective components connected to PE may be disconnected for this test</p> <p>b) between each combination of separate isolated circuits of the SPD, if there is more than one.</p>	<p>a)Between enclosure and live parts</p> <p>b)Between the live parts and live parts of remote terminal</p>	<p>P</p> <p>P</p>
	Pass criteria		
	<p>The insulation resistance shall not be lower than</p> <ul style="list-style-type: none"> • 5 MΩ for the measurements according to a), • 2 MΩ for the measurements according to b). 	<p>≥ 2000 MΩ</p> <p>≥ 2000 MΩ</p>	<p>P</p> <p>P</p>
8.3.7	Dielectric withstand		
	SPDs classified for outdoor use are tested between the terminals with the internal parts removed. During this test, the SPD is subjected to sprinkling according to 9.1 of IEC 60060-1.		P
	SPDs classified for indoor are tested as indicated in a) and b) of 8.3.6.		P

IEC 61643-11			
Clause	Requirement + Test	Result - Remark	Verdict

IEC 61643-11 - TEST SEQUENCE 3b Additional tests if declared by the manufacturer			
7.6.2.1/8.7.2	Test to determine the voltage drop (two port SPDs)		
	U _c supplied at the input port SPD loaded with rated load current into a resistive load Input and output voltage measured simultaneously to determine the percentage voltage regulation $\Delta U\% = ((U_{in} - U_{out}) / U_{in}) * 100\%$	_____ V _____ A _____ %	N/A
	Pass criteria		
C	No mechanical damage		N/A

IEC 61643-11			
Clause	Requirement + Test	Result - Remark	Verdict

IEC 61643-11 - TEST SEQUENCE 3c			
Additional tests for two-port SPDs with separate input / output terminals			
7.5.1.1/ 8.6.1.1	Rated load current (I_L)		
	The SPD shall be powered at a voltage U _C ⁺⁰ / ₋₅ % at ambient temperature, using a cable with a nominal cross-section as specified in Table 19. The test shall be conducted with rated load current into a resistive load until thermal stability is reached. Additional cooling of the SPD is not permitted.	_____ V _____ A _____ mm ²	N/A
	Pass criteria		
	Value complies with the manufacturers		N/A
	External disconnectors shall not operate during the test and shall be in working order after the test.		N/A
	Internal disconnectors shall not operate during the test and shall be in working order after the test.		N/A
	The temperature rise of surfaces which are accessible in normal use shall not exceed the values described in Annex G during the test. Parts of SPD: Built-in components Terminals for external insulated conductors Busbars and conductors, plug-in contacts of removable or withdrawable parts which connect to busbars Manual operating means of metal Manual operating means of insulating material Accessible external enclosures and covers <ul style="list-style-type: none"> - metal surfaces - insulating surfaces Discrete arrangements of plug and socket-type connections	Temperature rise: MAX. / MIN. _____ K / _____ K _____ K / _____ K _____ K / _____ K _____ K / _____ K _____ K / _____ K _____ K / _____ K _____ K / _____ K _____ K / _____ K	N/A

IEC 61643-11			
Clause	Requirement + Test	Result - Remark	Verdict

IEC 61643-11 - TEST SEQUENCE 3c			
<i>Additional tests for two-port SPDs with separate input / output terminals</i>			
	<p>The temperature rise of surfaces which are accessible in normal use shall not exceed the values described in Annex G during the test.</p> <p>Parts of SPD:</p> <ul style="list-style-type: none"> Built-in components Terminals for external insulated conductors Busbars and conductors, plug-in contacts of removable or withdrawable parts which connect to busbars Manual operating means of metal Manual operating means of insulating material Accessible external enclosures and covers <ul style="list-style-type: none"> - metal surfaces - insulating surfaces Discrete arrangements of plug and socket-type connections 	<p>Temperature rise:</p> <p>MAX. / MIN.</p> <p>____ K / ____ K</p> <p>____ K / ____ K</p> <p>____ K / ____ K</p> <p>____ K / ____ K</p> <p>____ K / ____ K</p> <p>____ K / ____ K</p> <p>____ K / ____ K</p> <p>____ K / ____ K</p>	N/A
7.5.1.2	Overload behaviour		
	The SPD shall be damaged or altered by overloads, which may occur in normal use.		
8.6.1.2	The test is carried out at ambient temperature and the sample shall be protected against abnormal external heating or cooling.		N/A
	The test is carried out at ambient temperature and the sample shall be protected against abnormal external heating or cooling.		N/A
	The test circuit and procedure shall be as described in 8.6.1.1, except that circuits other than the main circuit are disregarded for this test.		N/A
	The test is performed without any external disconnectors being connected (internal removable overcurrent protective devices are replaced by a link of negligible impedance).		N/A
	If a maximum overcurrent protection is specified by the manufacturer, the SPD shall be loaded for 1 h with a current equal to k times that maximum overcurrent protection. The factor k shall be selected from Table 20.	<p>k = ____</p> <p>I = ____ A</p>	N/A

IEC 61643-11			
Clause	Requirement + Test	Result - Remark	Verdict

IEC 61643-11 - TEST SEQUENCE 3c			
<i>Additional tests for two-port SPDs with separate input / output terminals</i>			
	<p>If no maximum overcurrent protection is specified by the manufacturer, the SPD shall be loaded with 1,1 times the rated load current for 1 h or until an internal disconnecter operates.</p> <p>If no disconnecter operates within 1 h, the test is continued by increasing the previous value of test current by a factor of 1,1 every hour, until an internal disconnecter operates.</p>	<p>_____ A</p> <p>1h → _____ A</p> <p>1h → _____ A</p>	<p>N/A</p> <p>N/A</p>
	Pass criteria		
	<p>The temperature rise of surfaces which are accessible in normal use shall not exceed the values described in ANNEX G during the test.</p> <p>Parts of SPD:</p> <p>Built-in SPD:</p> <p>Terminals for external insulated conductors</p> <p>Busbars and conductors, plug-in contacts of removable or withdrawable parts which connect to busbars</p> <p>Manual operating means of metal</p> <p>Manual operating means of insulating material</p> <p>Accessible external enclosures and covers</p> <ul style="list-style-type: none"> - metal surfaces - insulating surfaces <p>Discrete arrangements of plug and socket-type connections</p>	<p>Temperature rise:</p> <p>MAX. / MIN.</p> <p>_____ K / _____ K</p> <p>_____ K / _____ K</p> <p>_____ K / _____ K</p> <p>_____ K / _____ K</p> <p>_____ K / _____ K</p> <p>_____ K / _____ K</p> <p>_____ K / _____ K</p> <p>_____ K / _____ K</p>	<p>N/A</p>

IEC 61643-11			
Clause	Requirement + Test	Result - Remark	Verdict

IEC 61643-11 - TEST SEQUENCE 3c			
<i>Additional tests for two-port SPDs with separate input / output terminals</i>			
	<p>The temperature rise of surfaces which are accessible in normal use shall not exceed the values described in ANNEX G during the test.</p> <p>Parts of SPD:</p> <p>Built-in SPD:</p> <p>Terminals for external insulated conductors</p> <p>Busbars and conductors, plug-in contacts of removable or withdrawable parts which connect to busbars</p> <p>Manual operating means of metal</p> <p>Manual operating means of insulating material</p> <p>Accessible external enclosures and covers</p> <ul style="list-style-type: none"> - metal surfaces - insulating surfaces <p>Discrete arrangements of plug and socket-type connections</p>	<p>Temperature rise:</p> <p>MAX. / MIN.</p> <p>____ K / ____ K</p> <p>____ K / ____ K</p> <p>____ K / ____ K</p> <p>____ K / ____ K</p> <p>____ K / ____ K</p> <p>____ K / ____ K</p> <p>____ K / ____ K</p>	N/A
	a) Any internal disconnecter has operated:		
C	No mechanical damage		N/A
H	Disconnection shall be provided by one or more internal or external disconnecter(s). Their correct indication shall be checked.	_____	N/A
I	SPDs having an IP degree \geq IP 2X – no live parts accessible with standardised test finger applied with a force of 5N, except the ones which are accessible when the SPD is fitted as in normal use.		N/A
J	<p>If disconnection occurs during the test, there shall be clear evidence of effective disconnection of the corresponding protective component(s).</p> <p>If internal disconnection occurs, the test sample is connected at U_c and rated frequency for 1 min.</p> <p>The current flow shall not exceed a value of 1 mA.</p>	<p>_____ V</p> <p>_____ μA</p>	N/A
	Currents through components connected in parallel to the relevant protective component(s), are disregarded for this measurement.		N/A
	<p>Current through the PE-terminal shall not exceed 1mA</p> <p>If there is more than one possible connection arrangement for normal use, this check shall be performed for all arrangements.</p>	_____ μ A	N/A N/A

IEC 61643-11			
Clause	Requirement + Test	Result - Remark	Verdict

IEC 61643-11 - TEST SEQUENCE 3c			
<i>Additional tests for two-port SPDs with separate input / output terminals</i>			
M	There shall be no explosion or other hazard to either personnel or the facility.		N/A
	b) No internal disconnecter has operated:		
C	No mechanical damage		N/A
D	Determination of the measured limiting voltage:	$U_P \leq \text{_____ V}$	N/A
	according to 8.3.3.1, but only at a crest value corresponding to I_{imp} for test class I	$\text{_____ kA} / \text{_____ V}$	N/A
	according to 8.3.3.1, but only at I_n for test class II	$\text{_____ kA} / \text{_____ V}$	N/A
	according to 8.3.3.3, but only at U_{OC} for test class III	$\text{_____ kA} / \text{_____ V}$	N/A
	SPDs tested acc. to class I and II containing switching components: Front-of-wave sparkover voltage acc. to 8.3.3.2 All measured peak values (5 pos./5 neg.) below U_P	_____ kV	N/A
E	No excessive leakage currents shall occur after the test		N/A
	If there is more than one possible connection arrangement for normal use, this check shall be performed for all arrangements		N/A
	The SPD shall be connected as for normal use according to the manufacturer's instructions to a power supply at the reference test voltage (U_{REF}). The current that flows through each terminal is measured. Its resistive component (measured at the crest of the sine wave) shall not exceed a value of 1 mA or the current shall not have changed by more than 20% compared to the initial value determined at the beginning of the test sequence	$U_{REF} = \text{_____ V}$ _____ mA	N/A N/A N/A

IEC 61643-11			
Clause	Requirement + Test	Result - Remark	Verdict

IEC 61643-11 - TEST SEQUENCE 3c			
<i>Additional tests for two-port SPDs with separate input / output terminals</i>			
	Any resettable or rearmable disconnecter shall be switched off and dielectric withstand shall be checked by application of two times U_c or 1000V a.c. whichever is greater. During the test, no flashover, breakdown of insulation or any other manifestation of disruptive discharge shall occur.	$U_c = \underline{\hspace{2cm}} \text{ V}$ test voltage $\underline{\hspace{2cm}} \text{ V}$	N/A N/A
	For SPD modes connected N-PE only, the current through the PE-terminal shall be measured, whereas the terminals are connected to a power supply at U_c . Its resistive component (measured at the crest of the sine wave) shall not exceed a value of 1 mA or the current shall not have changed by more than 20% compared to the initial value determined at the beginning of the test sequence	$U_c = \underline{\hspace{2cm}} \text{ V}$ $I_{PE} = \underline{\hspace{2cm}} \text{ mA}$	N/A N/A N/A
I	SPDs having an IP degree \geq IP 2X – no live parts accessible with standardised test finger applied with a force of 5N, except the ones which are accessible when the SPD is fitted as in normal use.		N/A

IEC 61643-11			
Clause	Requirement + Test	Result - Remark	Verdict

IEC 61643-11 - TEST SEQUENCE 4			
7.4.2/8.5.2	Heat resistance		
	The SPD is kept in a heated cabinet at a temperature of $100\text{ }^{\circ}\text{C} \pm 2\text{ K}$ for the duration of 1 h.	<u>100 °C</u> for 1h	P
	Pass criteria		
C	No mechanical damage		P
I	SPDs having an IP degree \geq IP 2X – no live parts accessible with standardised test finger applied with a force of 5 N, except the ones which are accessible when the SPD is fitted as in normal use.		P
	Any sealing compound (including potting) used in the internal assembly shall not move to such an extent as to create a problem for the functionality of the SPD.		N/A
	The SPD is deemed to have passed the test even if a disconnecter has opened.		N/A
7.2.8	Behaviour under temporary overvoltages		
	SPDs for TT-systems between neutral and PE upstream the main RCD shall pass the TOV withstand mode criteria given 8.3.8.2.		N/A
7.2.8.1/8.3.8.1	TOVs caused by faults or disturbances in the low voltage system		
	For SPDs with a U_c greater than or equal to U_T there is no need to perform this test	$U_c = 385V$ $U_T = 336.6(5s)$ $U_T = 441.67V(120min)$	P
	SPDs shall be tested using either the TOV voltages U_T given in the relevant tables of Annex B, or, TOV voltages stated by the manufacturer according to 7.1.1 c1), whichever values are higher.	$U_T = 441.67V(120min)$	P

IEC 61643-11			
Clause	Requirement + Test	Result - Remark	Verdict

IEC 61643-11 - TEST SEQUENCE 4			
	Table B.1 shall be applied to all SPDs Depending on the information given by the manufacturer on 7.1.1 c1), the additional tables according to Clause B.1 of Annex B shall also be applied. For North American systems – Table B.2 For Japanese systems – Table B.3	under consideration	P N/A N/A
	New samples shall be used and fitted as in normal use, according to the manufacturer's instructions		P
	The test sample shall be connected to a power frequency voltage of $U_T^{+0/-5\%}$ for a duration $t_T^{+5/-0\%}$.		P
	Except for loss of neutral tests, this power source for U_T , shall be capable of delivering a current high enough to ensure that the voltage at the SPD terminals does not fall below U_T by more than 5 % during the test. For loss of neutral tests this voltage source shall be capable of delivering a prospective short-circuit current of 10A.		P
	Immediately following the application of U_T , a voltage equal to $U_{REF}^{+0/-5\%}$ with the same current capability, shall be applied to the test sample for a period of 15 min $^{+5/-0\%}$.	$U_{REF} = 255 \text{ V}$	P
	For loss of neutral tests, this power source for U_{REF} shall be capable of delivering a prospective short-circuit current equal to the declared short-circuit current rating of the SPD.		P
	The time interval between the test periods shall be as short as possible and shall in any case not exceed 100 ms.	<u>40</u> ms	P
a)	Pass criteria TOV failure mode		
C	No mechanical damage		N/A
H	Disconnection shall be provided by one or more internal or external disconnecter(s). Their correct indication shall be checked.	—	N/A
I	SPDs having an IP degree \geq IP 2X – no live parts accessible with standardised test finger applied with a force of 5N, except the ones which are accessible when the SPD is fitted as in normal use.		N/A

IEC 61643-11			
Clause	Requirement + Test	Result - Remark	Verdict

IEC 61643-11 - TEST SEQUENCE 4			
J	<p>If disconnection occurs during the test, there shall be clear evidence of effective disconnection of the corresponding protective component(s).</p> <p>If internal disconnection occurs, the test sample is connected at U_C and rated frequency for 1 min.</p> <p>The current flow shall not exceed a value of 1 mA.</p>	<p>_____ V</p> <p>_____ μA</p>	N/A
	Currents through components connected in parallel to the relevant protective component(s), are disregarded for this measurement.		N/A
	Current through the PE-terminal shall not exceed 1mA	_____ μ A	N/A
	If there is more than one possible connection arrangement for normal use, this check shall be performed for all arrangements.		N/A
K	The short-circuit current from the power source, if any, shall be interrupted within 5 s by one or more internal and/or external disconnector(s).		N/A
L	The tissue paper shall not catch fire.		N/A
M	There shall be no explosion or other hazard to either personnel or the facility		N/A
b)	Pass criteria TOV withstand mode	$U_T = 441.67V(120min)$	
A	Thermal stability shall be achieved		P
B	Voltage and current records and visual inspection show no sign of puncture or flashover.		P
C	No mechanical damage		P
D	Determination of the measured limiting voltage:	$U_P : 1.80kV$	
	according to 8.3.3.1, but only at a crest value corresponding to I_{imp} for test class I	<u>2.25kA</u> / <u>1.15KV</u>	P
	according to 8.3.3.1, but only at I_n for test class II	<u>20.0kA</u> / <u>1.64kV</u>	P
	according to 8.3.3.3, but only at U_{oc} for test class III	_____ kV / _____ V	N/A
	<p>SPDs tested acc. to class I and II containing switching components:</p> <p>Front-of-wave sparkover voltage acc. to 8.3.3.2</p> <p>All measured peak values (5 pos./5 neg.) below U_P</p>	_____ kV	N/A
E	No excessive leakage currents shall occur after the test		

IEC 61643-11			
Clause	Requirement + Test	Result - Remark	Verdict

IEC 61643-11 - TEST SEQUENCE 4			
	If there is more than one possible connection arrangement for normal use, this check shall be performed for all arrangements		P
	The SPD shall be connected as for normal use according to the manufacturer's instructions to a power supply at the reference test voltage (U_{REF}). The current that flows through each terminal is measured. Its resistive component (measured at the crest of the sine wave) <ul style="list-style-type: none"> shall not exceed a value of 1 mA or <ul style="list-style-type: none"> the current shall not have changed by more than 20% compared to the initial value determined at the beginning of the test sequence 	$U_{REF} = 255 \text{ V}$ 0.15 mA	P P N/A
	Any resettable or rearmable disconnecter shall be switched off and dielectric withstand shall be checked by application of two times U_C or 1000V a.c. whichever is greater. During the test, no flashover, breakdown of insulation or any other manifestation of disruptive discharge shall occur.	$U_C = \text{---} \text{ V}$ test voltage $\text{---} \text{ V}$	N/A N/A
	For SPD modes connected N-PE only, the current through the PE-terminal shall be measured, whereas the terminals are connected to a power supply at U_C . Its resistive component (measured at the crest of the sine wave) <ul style="list-style-type: none"> shall not exceed a value of 1 mA or <ul style="list-style-type: none"> the current shall not have changed by more than 20% compared to the initial value determined at the beginning of the test sequence 	$U_C = 385 \text{ V}$ $I_{PE} = 0.27 \text{ mA}$	P P N/A
F	External disconnectors shall not operate during the test and shall be in working order after the test.		N/A
G	Internal disconnectors shall not operate during the test and shall be in working order after the test.		P
I	SPDs having an IP degree \geq IP 2X – no live parts accessible with standardised test finger applied with a force of 5 N, except the ones which are accessible when the SPD is fitted as in normal use.		P

IEC 61643-11			
Clause	Requirement + Test	Result - Remark	Verdict

IEC 61643-11 - TEST SEQUENCE 4			
L	The tissue paper shall not catch fire.		P
M	There shall be no explosion or other hazard to either personnel or the facility		P
7.2.8.2/8.3.8.2	TOVs caused by faults in the high (medium) voltage system	SPD for TN system	
	SPDs connected to PE and for use on power distribution systems <ul style="list-style-type: none"> TOV voltages U_T given in Annex B or, <ul style="list-style-type: none"> TOV voltages stated by the manufacturer according to 7.1.1 c1) whichever values are higher.	$U_T = \text{---} V + U_{REF}$ $U_T = \text{---} V$	N/A N/A
	Table B.1 shall be applied to all SPDs Depending on the information given by the manufacturer on 7.1.1 c1), the additional tables according to Clause B.1 of Annex B shall also be applied. For North American systems – Table B.2 For Japanese systems – Table B.3		N/A N/A N/A
	New samples shall be used and fitted as in normal use, according to the manufacturer's instructions, and connected to a test circuit according to Figure 16 or equivalent		N/A
	The test voltage $U_T^{+0/-5\%}$ is applied to the test sample at 90 electrical degrees of phase L1 by closing switch S1.		N/A
	After the TOV application time $t_T^{+0/-5\%}$ switch S2 is closed automatically. This connects the SPD's PE-terminal to the neutral.		N/A
	Test circuit according to Figure 16 and Figure 17 or, alternative test circuit given in Annex E. Other test circuits are permitted as long as they ensure the same stress to the SPD.	—	N/A N/A N/A

IEC 61643-11			
Clause	Requirement + Test	Result - Remark	Verdict

IEC 61643-11 - TEST SEQUENCE 4			
	The prospective short-circuit current of the power source for U_{REF} shall be equal to five times the rated current of the maximum overcurrent protection is declared. The tolerance for the current is $+10/-0\%$.	_____A	N/A
	The prospective short-circuit current delivered by the TOV transformer shall be adjusted to 300A $+10/-0\%$ by R2.	_____ A	N/A
	With the exception of SPDs connected neutral to ground, U_{REF} remains applied to the test sample for 15 min without interruption until switch S1 is reopened.		N/A
a)	Pass criteria TOV failure mode		
C	No mechanical damage		N/A
H	Disconnection shall be provided by one or more internal or external disconnector(s). Their correct indication shall be checked.		N/A
I	SPDs having an IP degree \geq IP 2X – no live parts accessible with standardised test finger applied with a force of 5N, except the ones which are accessible when the SPD is fitted as in normal use.		N/A
J	If disconnection occurs during the test, there shall be clear evidence of effective disconnection of the corresponding protective component(s). If internal disconnection occurs, the test sample is connected at U_C and rated frequency for 1 min. The current flow shall not exceed a value of 1 mA.	_____ _____ VAC _____ μ A	N/A
	Currents through components connected in parallel to the relevant protective component(s), are disregarded for this measurement.		N/A
	Current through the PE-terminal shall not exceed 1mA If there is more than one possible connection arrangement for normal use, this check shall be performed for all arrangements.	_____ μ A	N/A
K	The short-circuit current from the power source, if any, shall be interrupted within 5 s by one or more internal and/or external disconnector(s).		N/A
L	The tissue paper shall not catch fire.		N/A

IEC 61643-11			
Clause	Requirement + Test	Result - Remark	Verdict

IEC 61643-11 - TEST SEQUENCE 4			
M	There shall be no explosion or other hazard to either personnel or the facility		N/A
b)	Pass criteria TOV withstand mode		
A	Thermal stability shall be achieved		N/A
B	Voltage and current records and visual inspection show no sign of puncture or flashover.		N/A
C	No mechanical damage		N/A
D	Determination of the measured limiting voltage:	$U_P :$ _____kV	
	according to 8.3.3.1, but only at a crest value corresponding to I_{imp} for test class I	_____kA / _____V	N/A
	according to 8.3.3.1, but only at I_n for test class II	_____kA / _____V	N/A
	according to 8.3.3.3, but only at U_{oc} for test class III	_____kV / _____V	N/A
	SPDs tested acc. to class I and II containing switching components: Front-of-wave sparkover voltage acc. to 8.3.3.2 All measured peak values (5 pos./5 neg.) below U_P	_____kV	N/A
E	No excessive leakage currents shall occur after the test		
	If there is more than one possible connection arrangement for normal use, this check shall be performed for all arrangements		N/A

IEC 61643-11			
Clause	Requirement + Test	Result - Remark	Verdict

IEC 61643-11 - TEST SEQUENCE 4			
L	The tissue paper shall not catch fire.		N/A
M	There shall be no explosion or other hazard to either personnel or the facility		N/A

IEC 61643-11			
Clause	Requirement + Test	Result - Remark	Verdict
IEC 61643-11 - TEST SEQUENCE 5			
7.2.5.3	Short-circuit current behaviour		
8.3.5.3	This test is not applied to SPDs which are either classified for outdoor use and for mounting out of reach, for connection N-PE in TN and/or TT systems only		N/A N/A
	The test sample shall be mounted in accordance with the manufacturer's published recommendations and connected with conductors of the maximum cross section according to 8.4.2, keeping the cables connecting the sample to a maximum length of 0,5 m each.		P
	Sample preparation		
	For SPDs with non-linear components connected in parallel, separate sets of three samples shall be prepared in the manner below for every current path of the SPD which contains one or more non-linear component in 3.1.4 and 3.1.5.		P
	Current paths containing voltage switching components with combined disconnecter function, having an impulse withstand voltage equal or greater than 6 kV and a dielectric withstand equal or greater than 2500 V/50 Hz for 1 min in normal operating condition, are tested without any preparation and only in conjunction with other current paths prepared in the manner described below. Voltage limiting components and voltage switching components described in 3.1.4 and 3.1.5 shall be replaced by appropriate copper blocks (dummies) ensuring that the internal connections and their cross-section and surrounding material (e.g. resins) and packaging are not changed.		P
	a) Test at the declared short-circuit current rating		
	The sample is connected to a power frequency source at U_{REF} . The prospective short-circuit current as declared by the manufacturer and with the corresponding power factor as given in Table 8 are adjusted at the SPD terminals.	$U_{REF}: \underline{255} \text{ V}$ $\underline{300} \text{ A}$ $\cos \varphi = \underline{0.95}$	P
	The test is carried out twice with U_{REF} applied at (45 ± 5) electrical degrees and at (90 ± 5) electrical degrees after the zero crossing of the voltage.		P

IEC 61643-11			
Clause	Requirement + Test	Result - Remark	Verdict

IEC 61643-11 - TEST SEQUENCE 5			
	If a replaceable or resettable internal or external disconnector operates, the relevant disconnector shall be replaced or reset each time. If the disconnector cannot be replaced or reset, the test is stopped.	<u>Internal disconnector operated</u>	P
	Pass criteria		
C	No mechanical damage		P
H	Disconnection shall be provided by one or more internal or external disconnector(s). Their correct indication shall be checked.	<u>Internal disconnector operated</u>	P
I	SPDs having an IP degree \geq IP 2X – no live parts accessible with standardised test finger applied with a force of 5N, except the ones which are accessible when the SPD is fitted as in normal use.		P
J	If disconnection occurs during the test, there shall be clear evidence of effective disconnection of the corresponding protective component(s). If internal disconnection occurs, the test sample is connected at U_c and rated frequency for 1 min. The current flow shall not exceed a value of 1 mA.	<u>Internal disconnector operated</u> <u>20.15 μA</u>	P P
	Currents through components connected in parallel to the relevant protective component(s), are disregarded for this measurement.		N/A
	Current through the PE-terminal shall not exceed 1mA If there is more than one possible connection arrangement for normal use, this check shall be performed for all arrangements.	_____ mA	N/A N/A
K	The short-circuit current from the power source, if any, shall be interrupted within 5 s by one or more internal and/or external disconnector(s).	<u>Internal disconnector operated</u> <u>3.57s</u>	P
M	There shall be no explosion or other hazard to either personnel or the facility		P
N	There shall be no flashover to the metallic screen and the 6 A gL/gG fuse connecting the screen shall not operate during the test.		P

IEC 61643-11			
Clause	Requirement + Test	Result - Remark	Verdict

IEC 61643-11 - TEST SEQUENCE 5			
	b) Test at low short-circuit current		
	A power frequency source at U_{REF} , having a prospective short-circuit current of five times the rated current of the maximum overcurrent protection (if declared by the manufacturer), and a power factor according to Table 8, shall be applied for $5 s \pm 0,5 s$. If no external overcurrent protection is required by the manufacturer, a prospective short-circuit current of 300 A is used.	$U_{REF} = \underline{\hspace{1cm}} V$ $\underline{\hspace{1cm}} A$ $\cos \varphi = \underline{\hspace{1cm}}$	N/A
	The test is carried out once with U_{REF} applied at (45 ± 5) electrical degrees after the zero crossing of the voltage.		N/A
	Pass criteria		
C	No mechanical damage		N/A
I	SPDs having an IP degree $\geq IP 2X$ – no live parts accessible with standardised test finger applied with a force of 5 N, except the ones which are accessible when the SPD is fitted as in normal use.		N/A
M	There shall be no explosion or other hazard to either personnel or the facility.		N/A
N	There shall be no flashover to the metallic screen and the 6 A gL/gG fuse connecting the screen shall not operate during the test.		N/A
	If disconnection occurs during the test:		
H	Disconnection shall be provided by one or more internal or external disconnectors. Their correct indication shall be checked.		N/A
J	If disconnection occurs during the test, there shall be clear evidence of effective disconnection of the corresponding protective component(s). If internal disconnection occurs, the test sample is connected at U_C and rated frequency for 1 min. The current flow shall not exceed a value of 1 mA.	$\underline{\hspace{1cm}} V$ $\underline{\hspace{1cm}} \mu A$	N/A N/A
	Currents through components connected in parallel to the relevant protective component(s), are disregarded for this measurement.		N/A
	Current through the PE-terminal shall not exceed 1mA If there is more than one possible connection arrangement for normal use, this check shall be performed for all arrangements.	$\underline{\hspace{1cm}} mA$	N/A N/A

IEC 61643-11			
Clause	Requirement + Test	Result - Remark	Verdict
IEC 61643-11 - TEST SEQUENCE 5			
J	<p>If disconnection occurs during the test, there shall be clear evidence of effective disconnection of the corresponding protective component(s).</p> <p>If internal disconnection occurs, the test sample is connected at U_C and rated frequency for 1 min.</p> <p>The current flow shall not exceed a value of 1 mA.</p>	<p>_____ V</p> <p>_____ μA</p>	N/A
	Currents through components connected in parallel to the relevant protective component(s), are disregarded for this measurement.		N/A
	<p>Current through the PE-terminal shall not exceed 1mA</p> <p>If there is more than one possible connection arrangement for normal use, this check shall be performed for all arrangements.</p>	_____ μ A	N/A
K	The short-circuit current from the power source, if any, shall be interrupted within 5 s by one or more internal and/or external disconnectors(s).	_____ms	N/A
8.3.5.3.1	Additional test for SPDs with I_{fi} lower than the declared short-circuit current rating (I_{SCCR})		
	This test is only performed if the declared follow current interrupt rating I_{fi} is smaller than the test current.		N/A
	The sample is connected to a power frequency source at U_{REF} . The prospective short-circuit current as declared by the manufacturer and with the corresponding power factor as given in Table 8 are adjusted at the SPD terminals.	<p>_____ V</p> <p>_____ kA</p> <p>$\cos \varphi =$ _____</p>	N/A
	The voltage switching component(s) of the SPD is triggered with a positive surge current (8/20 or other appropriate waveshape) at (35 ± 5) electrical degrees after the zero crossing of the voltage on the positive half wave. The surge current shall be high enough to initiate a follow current but shall in no case exceed I_n .		N/A
	The test is carried out twice.		N/A
	To ensure that no external disconnector operates due to the trigger surge, all external disconnectors shall be placed in series with the power frequency source as shown in Figure 11.		N/A
	If a replaceable or resettable internal disconnector operates, the relevant disconnector shall be replaced or reset each time. If the disconnector cannot be replaced or reset, the test is stopped.		N/A

IEC 61643-11			
Clause	Requirement + Test	Result - Remark	Verdict

IEC 61643-11 - TEST SEQUENCE 5			
	Pass criteria		
C	No mechanical damage		N/A
H	Disconnection shall be provided by one or more internal or external disconnecter(s). Their correct indication shall be checked.		N/A
I	SPDs having an IP degree \geq IP 2X – no live parts accessible with standardised test finger applied with a force of 5 N, except the ones which are accessible when the SPD is fitted as in normal use.		N/A
J	If disconnection occurs during the test, there shall be clear evidence of effective disconnection of the corresponding protective component(s). If internal disconnection occurs, the test sample is connected at U_c and rated frequency for 1 min. The current flow shall not exceed a value of 1 mA.	_____ V _____ mA	N/A
	Currents through components connected in parallel to the relevant protective component(s), are disregarded for this measurement.		N/A
	Current through the PE-terminal shall not exceed 1mA If there is more than one possible connection arrangement for normal use, this check shall be performed for all arrangements.	_____ mA	N/A N/A
K	The short-circuit current from the power source, if any, shall be interrupted within 5 s by one or more internal and/or external disconnecter(s).		N/A
M	There shall be no explosion or other hazard to either personnel or the facility		N/A
N	There shall be no flashover to the metallic screen and the 6 A gL/gG fuse connecting the screen shall not operate during the test.		N/A
8.3.5.3.2	Additional test for SPD's failure mode simulation		
	For this test any electronic indicator circuitry may be disconnected.		N/A
	New samples shall be used and fitted as in normal use, acc. to the manufacturer's instructions and connected with conductors of the maximum cross section acc. to 8.4.2. The maximum length of the cables connection the sample shall be of 0,5 m each.		P

IEC 61643-11			
Clause	Requirement + Test	Result - Remark	Verdict

IEC 61643-11 - TEST SEQUENCE 5			
	External disconnectors, if recommended by the manufacturer, shall be used.	—	N/A
	<p>The test sample shall be connected to a power frequency voltage source at the following conditioning voltages:</p> <ul style="list-style-type: none"> SPDs rated U_C up to 440V, apply a voltage equal to $1200 V_{rms}^{+5/-0\%}$ SPDs with U_C rated above 440V, apply a voltage equal to 3 times $U_C^{+5/-0\%}$ 	<u>1200 V</u>	P N/A
	The conditioning voltage is applied for a duration of $5 s^{+5/-0\%}$. The prospective short-circuit current of this power source for conditioning shall be adjusted to a value between 1 A and $20 A_{rms}^{+5/-0\%}$, as provided by the manufacturer according to 7.1.1 d5).	<u>1A</u>	P
	Following the application of the conditioning voltage equal to $U_{REF}^{+0/-5\%}$ with a short-circuit current capability as given below, shall be applied to the sample for a period of $5 min^{+5/-0\%}$ or for at least 0,5 s after interruption of the current by an internal or external disconnector.		P
	The transition from conditioning voltage application to U_{REF} application shall be performed without interruption. The current flow through the SPD shall be monitored. An appropriate test circuit and timing diagram is shown in Figure 12 and Figure 13.		P
	The prospective short-circuit current of the power source at U_{REF} shall have a tolerance of $+5/-0\%$ at the location where the SPD is connected. The power factor of the power source shall comply with Table 8.		P
	Each of the following tests shall be performed on a new set of three preconditioned samples as above at U_{REF} with a short-circuit current of 100A, 500A and 1000A, respectively, unless these values exceed the declared short-circuit rating of the SPD.	<u>100 A</u>	P
	A further test shall be performed on three preconditioned samples as above and at U_{REF} with a prospective short-circuit current equal to the manufacturer's declared short-circuit current rating. For this test, the time interval between the completion of the conditioning test and the application of U_{REF} shall be as short as possible and shall not exceed 100 ms.	The current through the sample during the application of U_{REF} after conditioning does not exceed <u>0.14mA</u>	N/A

IEC 61643-11			
Clause	Requirement + Test	Result - Remark	Verdict

IEC 61643-11 - TEST SEQUENCE 5			
	If all oscillograms of the tests on the first set of samples (100 A test set up) show a disconnection within 5 s during the application of the conditioning voltage, no further test is performed.	_____	N/A
	Pass criteria		
	For this test any damage to electronic indicator circuitry during the conditioning test is not regarded as a failure.		
C	No mechanical damage		P
I	SPDs having an IP degree \geq IP 2X – no live parts accessible with standardised test finger applied with a force of 5 N, except the ones which are accessible when the SPD is fitted as in normal use.		P
M	There shall be no explosion or other hazard to either personnel or the facility		P
N	There shall be no flashover to the metallic screen and the 6 A gL/gG fuse connecting the screen shall not operate during the test.		P
	Additional pass criteria except for: <ul style="list-style-type: none"> short circuiting type SPDs SPDs where the current is interrupted during the application of U_{REF} where no disconnection occurs.	SPDs where the current is interrupted during the application of U_{REF} where no disconnection occurs.	P
H	Disconnection shall be provided by one or more internal or external disconnecter(s). Their correct indication shall be checked.	_____	N/A
J	If disconnection occurs during the test, there shall be clear evidence of effective disconnection of the corresponding protective component(s). If internal disconnection occurs, the test sample is connected at U_C and rated frequency for 1 min. The current flow shall not exceed a value of 1 mA.	_____ _____ _____ V _____ _____ μ A	N/A
	Currents through components connected in parallel to the relevant protective component(s), are disregarded for this measurement.		N/A
	Current through the PE-terminal shall not exceed 1mA If there is more than one possible connection arrangement for normal use, this check shall be performed for all arrangements.	_____ μ A	N/A N/A

IEC 61643-11			
Clause	Requirement + Test	Result - Remark	Verdict

IEC 61643-11 - TEST SEQUENCE 6			
<i>Additional tests if declared by the manufacturer</i>			
7.6.1.1/8.7.1	Total discharge current test for multipole SPDs		
	One side of the test generator is connected to the PE or PEN terminal of the multipole SPD. Each of the remaining SPD terminals is connected via a typical series impedance consisting of a resistance of 30 mΩ and an inductance of 25 μH, to the other side of the generator. Smaller impedances may be used if the tolerances for the proportional surge currents according to Table 21 are met.		N/A
	The multipole SPD shall be tested once with the total discharge current I_{Total} declared by the manufacturer.	_____ kA	N/A
	Pass criteria		
B	Voltage and current records and visual inspection show no sign of puncture or flashover.		N/A
C	No mechanical damage		N/A
D	Determination of the measured limiting voltage:	$U_P \leq$ _____ V	
	according to 8.3.3.1, but only at a crest value corresponding to I_{imp} for test class I	_____ kA / _____ V	N/A
	according to 8.3.3.1, but only at I_n for test class II	_____ kA / _____ V	N/A
	according to 8.3.3.3, but only at U_{oc} for test class III	_____ kA / _____ V	N/A
	SPDs tested acc. to class I and II containing switching components: Front-of-wave sparkover voltage acc. to 8.3.3.2 All measured peak values (5 pos./5 neg.) below U_P	_____ kV	N/A
E	No excessive leakage currents shall occur after the test		N/A
	If there is more than one possible connection arrangement for normal use, this check shall be performed for all arrangements		N/A

IEC 61643-11			
Clause	Requirement + Test	Result - Remark	Verdict
IEC 61643-11 - TEST SEQUENCE 6 Additional tests if declared by the manufacturer			
	<p>The SPD shall be connected as for normal use according to the manufacturer's instructions to a power supply at the reference test voltage (U_{REF}).</p> <p>The current that flows through each terminal is measured. Its resistive component (measured at the crest of the sine wave)</p> <ul style="list-style-type: none"> • shall not exceed a value of 1 mA <p>or</p> <ul style="list-style-type: none"> • the current shall not have changed by more than 20% compared to the initial value determined at the beginning of the test sequence 	$U_{REF} = \text{_____ V}$	N/A N/A N/A
	<p>Any resettable or rearmable disconnecter shall be switched off and dielectric withstand shall be checked by application of two times U_C or 1000V a.c. whichever is greater.</p> <p>During the test, no flashover, breakdown of insulation or any other manifestation of disruptive discharge shall occur.</p>	$U_C = \text{_____ V}$ test voltage _____ V	N/A N/A
	<p>For SPD modes connected N-PE only, the current through the PE-terminal shall be measured, whereas the terminals are connected to a power supply at U_C.</p> <p>Its resistive component (measured at the crest of the sine wave)</p> <ul style="list-style-type: none"> • shall not exceed a value of 1 mA <p>or</p> <ul style="list-style-type: none"> • the current shall not have changed by more than 20% compared to the initial value determined at the beginning of the test sequence 	$U_C = \text{_____ V}$ $I_{PE} = \text{_____ mA}$	N/A N/A N/A
G	Internal disconnectors shall not operate during the test and shall be in working order after the test.		N/A
I	SPDs having an IP degree \geq IP 2X – no live parts accessible with standardised test finger applied with a force of 5N, except the ones which are accessible when the SPD is fitted as in normal use.		N/A
M	There shall be no explosion or other hazard to either personnel or the facility		N/A

IEC 61643-11			
Clause	Requirement + Test	Result - Remark	Verdict

IEC 61643-11 - TEST SEQUENCE 7 Additional tests for outdoor use SPDs			
7.5.2/8.6.2	Environmental tests for outdoor SPDs (informative)		
F.1	Accelerated aging test with UV radiation		
	Expose three complete SPDs, as to be installed for outdoor use, to 1000 h of UV radiation (UV-B) and water spray as follows: 500 cycles of 120 min each, consisting of 102 min of UV light at 60 °C, 18 min of UV light and water spray at 65 °C and 65 % RH. The UV radiation shall be according to ISO 4892-2, method A. ISO 4892-1 and ASTM 151 are to be used for general guidance for the test.		N/A
	The samples shall be connected to a power source at U_c during the test and residual current shall be monitored at 120 min intervals. After completion of this test, the samples shall be tested according to F.2.		N/A
	Pass criteria		
	During and after the test the samples shall be visually inspected for voids, cracks, tracking and surface erosion. The residual currents shall not increase by more than 10%. The degree of tracking, surface erosion and cracking shall be assessed to determine if this will compromise the enclosure of the product to meet the other electrical and mechanical performance requirements of this standard.		N/A
F.2	Water immersion test		
	The test is performed in accordance with Figure 8 of IEC 60099-4. The test samples shall kept immersed in a vessel, in boiling de-ionized water with 1 kg/m ³ of NaCl, for 42 h.		N/A
	At the end of boiling, the SPD shall remain in the vessel until the water has cooled down to approximately 20 °C (\pm 15 °C) and shall be maintained in the water till the verification tests are performed. After the water immersion test the samples shall be subjected the dielectric test (see F.3).		N/A

IEC 61643-11			
Clause	Requirement + Test	Result - Remark	Verdict

IEC 61643-11 - TEST SEQUENCE 7 Additional tests for outdoor use SPDs			
F.3	Dielectric test		
	<p>The test samples shall be subjected to a dielectric test at a power frequency sinusoidal voltage of 1000 V plus twice the reference test voltage U_{REF} for 1 min and the leakage current shall be measured. The test voltage shall be applied as follows:</p> <p>a) SPD with metallic housing with or without mounting bracket</p> <p>The voltage shall be applied between all terminals or external leads which are not internally connected to the housing, neither directly nor through surge protective components, connected together, and the metallic housing. If all terminals and external leads are connected directly or through components to the conductive housing, this test is not performed.</p> <p>b) SPD with non-conductive housing with non-conductive or without mounting bracket</p> <p>The non-conductive housing shall be tightly wrapped in conductive foil to within 15 mm of any non-insulated lead or terminal. The voltage shall be applied between the conductive foil and all terminals or external leads connected together.</p> <p>c) SPD with non-conductive housing with metallic mounting bracket</p> <p>The non-conductive housing shall be tightly wrapped in conductive foil to within 15 mm of any non-insulated lead, terminal and the metallic mounting bracket. The voltage shall be applied between the conductive foil and all terminals, external leads and mounting bracket connected together.</p>		N/A
	Pass criteria		
	The leakage current measured during this test shall not exceed 25 mA.	$I = \text{_____ mA}$	N/A
F.4	Temperature cycle test		
	The test shall be performed according to IEC 60068-2-14 with 5 cycles with a lower temperature of -40 °C and with an upper temperature of +100 °C. The time duration for each half cycle is 3 h and the temperature change shall occur within 30 s.	<p>_____ °C</p> <p>_____ °C</p> <p>5 cycles</p>	N/A

IEC 61643-11			
Clause	Requirement + Test	Result - Remark	Verdict

IEC 61643-11 - TEST SEQUENCE 7 Additional tests for outdoor use SPDs			
	Pass criteria		
	During and after the test, the samples shall be visually inspected for voids, cracks, tracking and surface erosion. The residual currents shall not increase by more than 10 %. The degree of tracking, surface erosion and cracking shall be assessed to determine if this will compromise the enclosure of the product to meet the other electrical and mechanical performance requirements of this standard.		N/A
F.5	Verification of resistance to corrosion		
	SPDs with exposed metal parts shall be subjected to the test and shall be mounted as for normal use according to the manufacturer's instructions. The enclosure or samples shall be new and in a clean condition. The samples shall be subjected to the following test:		N/A
	<ul style="list-style-type: none"> 12 cycles of 24 h, damp heat cycling test according to test Db of IEC 60068-2-30 at 40 °C and relative humidity of 95 %; 14 cycles of 24 h, salt mist test according to test Ka of IEC 60068-2-11 at a temperature of (35 ± 2) °C. 		N/A
	After the test, the samples shall be washed in running tap water for 5 min, rinsed in distilled or demineralized water then shaken or subjected to air blast to remove water droplets. The specimen under test shall then be stored under normal service conditions for 2 h.		N/A
	Pass criteria		
	Compliance is checked by visual inspection to ensure that:		N/A
	<ul style="list-style-type: none"> there is no evidence of rust, cracking or other deterioration. However, surface deterioration of any protective coating is allowed. In case of doubt, reference shall be made to ISO 4628-3 to verify that the samples conform to the specimen Ri1; seals are not damaged; any moving parts (disconnectors) work without abnormal effort. 		N/A
			N/A

IEC 61643-11			
Clause	Requirement + Test	Result - Remark	Verdict

IEC 61643-11 - TEST SEQUENCE 8			
Additional tests for short-circuiting type SPDs			
7.5.4/8.6.4	Short-circuiting type SPDs		
	<p>These SPDs shall be capable of withstanding a short-circuit current test at their declared short-circuit current rating after having been overstressed by a surge current according to their transition rating I_{trans}.</p> <p>For such SPD's a conditioning into an intentional short-circuit according 8.6.4.1 is carried out, followed by a surge withstand test according 8.6.4.2 and a short-circuit current behaviour test according 8.6.4.3.</p>		N/A
8.6.4.1	Change of characteristic procedure (conditioning test)		
	<p>One impulse of I_{trans} with positive polarity is applied to the de-energised SPD to change of characteristic of the SPD into an internal short-circuit. To check for the internal short-circuit an appropriate measurement shall be performed after this test.</p>	$I_{trans} = \text{_____ kA}$	N/A
8.6.4.2	Surge withstand test (in short-circuited condition)		
	<p>One impulse of I_{trans} with positive polarity is applied to the de-energised SPD.</p>		N/A
	Pass criteria		
C	No mechanical damage		N/A
I	SPDs having an IP degree \geq IP 2X – no live parts accessible with standardised test finger applied with a force of 5N, except the ones which are accessible when the SPD is fitted as in normal use.		N/A
M	There shall be no explosion or other hazard to either personnel or the facility		N/A
8.6.4.3	Short-circuit current behaviour test (in short-circuited condition)		
	<p>The test is performed according to 8.3.5.3 excluding 8.3.5.1 and 8.3.5.3.2, but without any sample preparation.</p>		N/A
8.3.5.3	<p>This test is not applied to SPDs which are either</p> <ul style="list-style-type: none"> classified for outdoor use and for mounting out of reach, for connection N-PE in TN and/or TT systems only 		N/A N/A

IEC 61643-11			
Clause	Requirement + Test	Result - Remark	Verdict

IEC 61643-11 - TEST SEQUENCE 8			
Additional tests for short-circuiting type SPDs			
	The test sample shall be mounted in accordance with the manufacturer's published recommendations and connected with conductors of the maximum cross section according to 8.4.2, keeping the cables connecting the sample to a maximum length of 0,5 m each.		N/A
	a) Test at the declared short-circuit current rating		
	The sample is connected to a power frequency source at U_{REF} . The prospective short-circuit current as declared by the manufacturer and with the corresponding power factor as given in Table 8 are adjusted at the SPD terminals.	_____ V _____ kA cos φ = _____	N/A
	The test is carried out twice with U_{REF} applied at (45 ± 5) electrical degrees and at (90 ± 5) electrical degrees after the zero crossing of the voltage.		N/A
	If a replaceable or resettable internal or external disconnector operates, the relevant disconnector shall be replaced or reset each time. If the disconnector cannot be replaced or reset, the test is stopped.	_____	N/A
	b) Test at low short-circuit current		
	A power frequency source at U_{REF} , having a prospective short-circuit current of five times the rated current of the maximum overcurrent protection (if declared by the manufacturer), and a power factor according to Table 8, shall be applied for $5 \text{ s} \pm 0,5 \text{ s}$. If no external overcurrent protection is required by the manufacturer, a prospective short-circuit current of 300 A is used.	_____ V _____ kA cos φ = _____	N/A
	The test is carried out twice with U_{REF} applied at (45 ± 5) electrical degrees after the zero crossing of the voltage.		N/A
	Pass criteria		
C	No mechanical damage		N/A
H	Disconnection shall be provided by one or more internal or external disconnector(s). Their correct indication shall be checked.		N/A
I	SPDs having an IP degree \geq IP 2X – no live parts accessible with standardised test finger applied with a force of 5N, except the ones which are accessible when the SPD is fitted as in normal use.		N/A

IEC 61643-11			
Clause	Requirement + Test	Result - Remark	Verdict

IEC 61643-11 - TEST SEQUENCE 8			
Additional tests for short-circuiting type SPDs			
J	<p>If disconnection occurs during the test, there shall be clear evidence of effective disconnection of the corresponding protective component(s).</p> <p>If internal disconnection occurs, the test sample is connected at U_c and rated frequency for 1 min.</p> <p>The current flow shall not exceed a value of 1 mA.</p>	<p>_____ V</p> <p>_____ mA</p>	N/A
	Currents through components connected in parallel to the relevant protective component(s), are disregarded for this measurement.		N/A
	<p>Current through the PE-terminal shall not exceed 1mA</p> <p>If there is more than one possible connection arrangement for normal use, this check shall be performed for all arrangements.</p>	_____ mA	N/A N/A
K	The short-circuit current from the power source, if any, shall be interrupted within 5 s by one or more internal and/or external disconnector(s).		N/A
M	There shall be no explosion or other hazard to either personnel or the facility		N/A
N	There shall be no flashover to the metallic screen and the 6 A gL/gG fuse connecting the screen shall not operate during the test.		N/A

Remarks: /

Table 3 – Type test requirements for SPDs

Test sequence	Test description	Subclause requirement/test	External disconnectors connected ^a	Tissue paper used	Metallic screen used	Test class I	Test class II	Test class III
1	Identification and marking	7.1.1/7.1.2/8.2	-	-	-	A	A	A
	Mounting	7.3.1	-	-	-	A	A	A
	Terminals and connections	7.3.2/7.3.3/8.4.2	-	-	-	A	A	A
	Testing for protection against direct contact	7.2.1/8.3.1	-	-	-	A	A	A
	Environment, IP code	7.4.1 / 8.5.1	-	-	-	A	A	A
	Residual current	7.2.2 / 8.3.2	-	-	-	A	A	A
	Operating duty test	7.2.4/8.3.4 ^b						
	Operating duty test for test classes I, II or III	8.3.4.2 / 8.3.4.3/ 8.3.4.5	A	-	-	A	A	A
	Additional duty test for test class I	8.3.4.4	A	-	-	A	-	-
	Thermal stability	7.2.5.2 / 8.3.5.2	A	-	-	A	A	A
	Air clearances and creepage distances	7.3.4 / 8.4.3	-	-	-	A	A	A
	Ball pressure test	7.4.2 / 8.5.3	-	-	-	A	A	A
	Resistance to abnormal heat and fire	7.4.3 / 8.5.4	-	-	-	A	A	A
	Tracking resistance	7.4.4 / 8.5.5	-	-	-	A	A	A
2	Voltage protection level	7.2.3/8.3.3						
	Residual voltage	8.3.3.1	-	-	-	A	A	-
	Front of wave sparkover voltage	8.3.3.2	-	-	-	A	A	-
	Limiting voltage with combination wave	8.3.3.3	-	-	-	-	-	A
2a	See below - only if applicable							
2b	See below - only if applicable							
3	Insulation resistance	7.2.6 / 8.3.6	-	-	-	A	A	A
	Dielectric withstand	7.2.7 / 8.3.7	-	-	-	A	A	A
3a	See below - only if applicable							
	Mechanical strength	7.3.5 / 8.4.4	-	-	-	A	A	A
	Temperature withstand	7.2.5 / 8.3.5.1 ^b	-	-	-	A	A	A
3b ^c	See below - only if applicable							
3c	See below - only if applicable							
4 ^c	Heat resistance	7.4.2 / 8.5.2	-	-	-	A	A	A
	TOV tests	7.2.8 / 8.3.8						
	TOVs caused by faults or disturbances in the low voltage system	7.2.8.1/8.3.8.1 ^b	A	A	-	A	A	A
	TOVs caused by faults in the high (medium) voltage system	7.2.8.2/8.3.8.2 ^b	A	A	-	A	A	A
5 ^c	Short-circuit current behaviour	7.2.5.3 / 8.3.5.3	A	-	A	A	A	A

Table 3 – Type test requirements for SPDs (continued)

Additional tests for specific SPD designs								
Test sequence	Test description	Subclause requirement/test	External disconnectors connected ^a	Tissue paper used	Metallic screen used	Test class I	Test class II	Test class III
Additional tests for two-port SPDs and one port-SPDs with separate input / output terminals								
3c ^c	Rated load current	7.5.1.1 / 8.6.1.1	A	-	-	A	A	A
	Overload behaviour	7.5.1.2 / 8.6.1.2 ^b	-	-	-	A	A	A
2b	Load side short-circuit current behaviour	7.5.1.3 / 8.6.1.3 ^b	A	-	A	A	A	A
Additional tests if declared by the manufacturer								
3b	Voltage drop	7.6.2.1 / 8.7.2	-	-	-	A	A	A
2a ^c	Load side surge withstand	7.6.2.2 / 8.7.3 ^b	A	-	-	A	A	A
6	Total discharge current test for multipole SPDs	7.6.1.1 / 8.7.1 ^b	-	-	-	A	A	-
Additional tests for outdoor use SPDs								
7	For SPDs classified "outdoor"	7.5.2 / 8.6.2	-	O	-	A	A	-
Additional tests for SPDs with separate isolated circuits								
3a	Isolation between separate circuits	7.5.3/ 8.3.6 / 8.3.7	-	-	-	A	A	A
Additional tests for short-circuiting type SPDs								
8	Change of characteristic procedure (preconditioning to short-circuited condition)	7.5.4 / 8.6.4	-	-	-	-	A	-
	Surge withstand test (in short-circuited condition)	7.5.4 / 8.6.4	-	-	-	-	A	-
	Short-circuit current behaviour (in short-circuited condition)	7.5.4 / 8.6.4	A	-	A	-	A	-
A = applicable								
- = not applicable								
O = optional								
^a external disconnectors connected means that all disconnectors as specified by the manufacturer shall be tested with the SPD during the type tests, except for RCDs, which are not tested during the operating duty test according to 8.3.4.								
^b For these tests initial measurements of leakage currents according to Table 4, pass criterion E may be necessary.								
^c For this test sequence more than one set of samples may be needed.								

Table 4 – Common pass criteria for type tests

A	Thermal stability shall be achieved. The SPD is considered to be thermally stable if the crest of the resistive component of the current flowing into the SPD or the power dissipation shows either a decreasing tendency or does not increase during 15 min of U_C voltage application immediately after the application of U_C . If the test itself is performed with the SPD energized at U_C , then U_C either remains applied for these 15 min without interruption or is reapplied within less than 30 s.
B	Voltage and current records and visual inspection shall show no indication of puncture or flashover.
C	No visible damage shall occur during the test. After the test, small indents and cracks not impairing the protection against direct contact are disregarded during this check, unless the degree of protection (IP-code) given for the SPD is no longer provided. There shall be no visual evidence of burning of the sample after the test.
D	Values for measured limiting voltage after the test shall be below or equal to U_P . The measured limiting voltage shall be determined, using the tests described in 8.3.3, but the test of 8.3.3.1 is performed only with a 8/20-surge current with a crest value of I_{imp} for Test Class I or with I_n for Test Class II or with the test of 8.3.3.3 but only at U_{OC} for Test class III.
E	No excessive leakage currents shall occur after the test. The SPD shall be connected as for normal use according to the manufacturer's instructions to a power supply at the reference test voltage (U_{REF}). The current that flows through each terminal is measured. Its resistive component (measured at the crest of the sine wave) shall not exceed a value of 1 mA, or the current shall not have changed by more than 20 % compared to the initial value determined at the beginning of the relevant test sequence. Any resettable or rearmable disconnecter shall be switched off manually, if applicable, and the dielectric withstand shall be checked by application of two times U_C or 1 000 V a.c., whichever is greater. During the test, no flashover, breakdown of insulation either internally (puncture) or externally (tracking) or any other manifestation of disruptive discharge shall occur. In addition for SPD modes connected N-PE only the current through the PE-terminal shall be measured, whereas the terminals are connected to a power supply at the maximum continuous operating voltage (U_C). Its resistive component (measured at the crest of the sine wave) shall not exceed a value of 1 mA, or the current shall not have changed by more than 20 % compared to the initial value determined at the beginning of the relevant test sequence. If there is more than one possible connection arrangement for normal use, this check shall be performed for all arrangements.
F	External disconnectors as specified by the manufacturer shall not operate during the test and shall be in working order after the test. For the purpose of this clause, working order means that there is no damage to the disconnector and that it is still operational. Operation can be checked either manually (where possible) or by a simple electrical test agreed between the manufacturer and the laboratory.
G	Internal disconnectors as specified by the manufacturer shall not operate during the test and shall be in working order after the test. For the purpose of this clause, working order means that there is no damage of the disconnector and that it is still operational. Operation can be checked either manually (where possible) or by a simple electrical test agreed between the manufacturer and the laboratory.
H	Disconnection shall be provided by one or more internal and/or external disconnector(s). Their correct indication shall be checked.
I	SPDs with an IP degree equal to, or greater than, IP20 shall not have live parts accessible with the standardized test finger applied with a force of 5 N (see IEC 60529), except the live parts which were already accessible before the test when the SPD is fitted as in normal use.
J	If disconnection (internal or external) occurs during the test, there shall be clear evidence of effective disconnection of the corresponding protective component(s). If internal disconnection occurs, the test sample is connected as for normal use at the maximum continuous operating voltage U_C and at rated frequency for 1 min. The test source shall have a short-circuit current capability equal or greater than 200 mA. The current that flows through the relevant protective components shall not exceed a value of 1 mA. Currents through components connected in parallel to the relevant protective component(s), or otherwise connected (e.g. indicator circuits), are disregarded for this measurement, as long as they cannot cause a current through the relevant protective component(s). In addition the current through the PE-terminal, including parallel circuits and other circuits (e.g. indicator circuits), if any, shall not exceed 1 mA. If there is more than one possible connection arrangement for normal use, this check shall be performed for all arrangements.
K	The short-circuit current from the power source, if any, shall be interrupted within 5 s by one or more internal and/or external disconnector(s).
L	The tissue paper shall not catch fire.
M	There shall be no explosion or other hazard to either personnel or the facility.
N	There shall be no flashover to the metallic screen and the 6 A gL/gG fuse connecting the screen shall not operate during the test.
O	After completion of this test the samples shall be allowed to return to room temperature and be connected to a power source at U_C for 2 h. The residual current shall be monitored and not exceed the value measured at the beginning of the test by more than 10 %.

Table 8 – Prospective short-circuit current and power factor

I_p (kA) $\begin{matrix} +5 \\ 0 \end{matrix}$ %	$\cos \varphi$ ($\begin{matrix} 0 \\ -0,05 \end{matrix}$)
$I_p \leq 1,5$	0,95
$1,5 < I_p \leq 3,0$	0,9
$3,0 < I_p \leq 4,5$	0,8
$4,5 < I_p \leq 6,0$	0,7
$6,0 < I_p \leq 10,0$	0,5
$10,0 < I_p \leq 20,0$	0,3
$20,0 < I_p \leq 50,0$	0,25
$50,0 < I_p$	0,2
NOTE Recovery voltage according to IEC 60947-1.	

Table 10 – Screw thread diameters and applied torques

Nominal diameter of thread mm	Torque Nm		
	I	II	III
Up to and including 2,8	0,2	0,4	0,4
Over 2,8 up to and including 3,0	0,25	0,5	0,5
Over 3,0 up to and including 3,2	0,3	0,6	0,6
Over 3,2 up to and including 3,6	0,4	0,8	0,8
Over 3,6 up to and including 4,1	0,7	1,2	1,2
Over 4,1 up to and including 4,7	0,8	1,8	1,8
Over 4,7 up to and including 5,3	0,8	2,0	2,0
Over 5,3 up to and including 6,0	1,2	2,5	3,0
Over 6,0 up to and including 8,0	2,5	3,5	6,0
Over 8,0 up to and including 10,0	–	4,0	10,0

Table 11 – Cross-sections of copper conductors for screw-type or screwless terminals

Maximum continuous load current for two-port SPDs or one-port SPDs with separate input/output terminals ^a A	Range of nominal cross-sections to be clamped (single conductor)	
	mm ²	American Wire Gauge
Up to and including 13	1 to 2,5	18 to 14
Above 13 up to and including 16	1 to 4	18 to 12
Above 16 up to and including 25	1,5 to 6	16 to 10
Above 25 up to and including 32	2,5 to 10	14 to 8
Above 32 up to and including 50	4 to 16	12 to 6
Above 50 up to and including 80	10 to 25	8 to 3
Above 80 up to and including 100	16 to 35	6 to 2
Above 100 up to and including 125	25 to 50	4 to 1

^a It is required that, for current ratings up to and including 50 A, terminals be designed to clamp solid conductors as well as rigid stranded conductors; the use of flexible conductors is permitted.

Nevertheless, it is permitted that terminals for conductors having cross-sections from 1 mm² up to 6 mm² be designed to clamp solid conductors only.

Table 12 – Pulling forces (screw terminals)

Cross-section of conductor accepted by the terminal mm ²	Up to 4	Up to 6	Up to 10	Up to 16	Up to 50
Pull N	50	60	80	90	100

Table 13 – Conductor dimensions

Range of nominal cross-sections to be clamped mm ²	Stranded conductor
	Number of wires
1 to 2,5 ^a	7
1 to 4 ^a	7
1,5 to 6 ^a	7
2,5 to 10	7
4 to 16	7
10 to 25	7
16 to 35	19
25 to 50	Under consideration

^a If the terminal is intended to clamp solid conductors only (see table footnote of Table 11), the test is not performed.

Table 14 – Pulling forces (screwless terminals)

Cross-sectional area mm ²	0,5	0,75	1,0	1,25 1,5	2,0 2,5	3,5 4	5,5 6	8,0 10	14 16	22 25	35 38
Pull force N	30	30	35	40	50	60	80	90	100	135	190

Table 15 – Air clearances for SPDs

U_{max}^a	$\leq 2\ 000\ V$	$\leq 4\ 000\ V$	$>4\ 000\ V$ up to 6 000 V	$>6\ 000\ V$ up to 8 000 V
	Air clearances in millimetres			
1) Between live parts of different polarity	1,5	3	5,5	8
2) Between live parts and				
– screws and other means to fasten a covering, having to be detached for mounting the SPD	1,5	3	5,5	8
– fastening surfaces (NOTE 2)	3	6	11	16
– screws or other means for fastening the SPD (NOTE 2)	3	6	11	16
– bodies (NOTES 1 and 2)	1,5	3	5,5	8
3) Between the metal parts of the disconnecter mechanism and				
– bodies (NOTE 1)	1,5	3	5,5	8
– screws or other means for fastening the SPD	1,5	3	5,5	8
^a This column is only applicable for SPDs with U_C lower or equal to 180 V.				
NOTE 1 For definition, see 8.3.6 a)				
NOTE 2 If clearances between live parts of the device and the metallic screen or the surface on which the SPD is mounted are dependent on the design of the SPD only and cannot be reduced when the SPD is mounted in the least favourable position (even in a metallic enclosure), the values of line 1) are sufficient.				

Table 16 – Creepage distances for SPDs

r.m.s. voltage <i>b, c</i>	Minimum creepage distances in millimetres									
	Printed wiring material		Pollution degree							
	Pollution degree		1	2	3			3		
	1	2	1	Material group ^a			Material group ^a			
V	All material groups	All material groups, except IIIb	All material groups	I	II	III	I	II	III ^d	
10	0,025	0,04	0,08	0,4	0,4	0,4	1	1	1	
12,5	0,025	0,04	0,09	0,42	4,42	4,42	1,0	1,05	1,05	
16	0,025	0,04	0,1	0,45	0,45	0,45	1,1	1,1	1,1	
20	0,025	0,04	0,11	0,48	0,48	0,48	1,2	1,2	1,2	
25	0,025	0,04	0,125	0,5	0,5	0,5	1,2	1,25	1,25	
32	0,025	0,04	0,14	0,53	0,53	0,53	1,3	1,3	1,3	
40	0,025	0,04	0,16	0,56	0,8	1,1	1,4	1,6	1,8	
50	0,025	0,04	0,18	0,6	0,85	1,2	1,5	1,7	1,9	
63	0,04	0,063	0,2	0,63	0,9	1,25	1,6	1,8	2	
80	0,063	0,1	0,22	0,67	0,95	1,3	1,7	1,9	2,1	
100	0,1	0,16	0,25	0,71	1	1,4	1,8	2	2,2	
125	0,16	0,25	0,28	0,75	1,05	1,5	1,9	2,1	2,4	
160	0,25	0,4	0,32	0,8	1,1	1,6	2	2,2	2,5	
200	0,4	0,63	0,42	1	1,4	2	2,5	2,8	3,2	
250	0,56	1	0,56	1,25	1,8	2,5	3,2	3,6	4	
320	0,75	1,6	0,75	1,6	2,2	3,2	4	4,5	5	
400	1	2	1	2	2,8	4	5	5,6	6,3	
500	1,3	2,5	1,3	2,5	3,6	5	6,3	7,1	8	
630	1,8	3,2	1,8	3,2	4,5	6,3	8	9	10	
800	2,4	4	2,4	4	5,6	8	10	11	12,5	
1 000	3,2	5	3,2	5	7,1	10	12,5	14	16	

^a For further information on material groups refer to Table 17.

^b This voltage is for functional insulation, the working voltage; for basic and supplementary insulation of the circuit energized directly from the supply mains, the voltage rationalized through Table F.3a or Table F.3b of IEC 60664-1, based on the rated voltage of the equipment, or the rated insulation voltage; for basic and supplementary insulation of systems, equipment and internal circuits not energized directly from the mains, the highest r.m.s. voltage which can occur in the system, equipment or internal circuit when supplied at rated voltage and under the most onerous combination of conditions of operation within equipment rating.

^c For the main protection circuit, this column refers to U_C .

^d Material IIIb shall not be used for application in pollution degree 3 above 630 V.

NOTE If the actual voltage differs from the values given in the table, it is allowed to interpolate values for intermediate voltages. When interpolating, linear interpolation should be used and values should be rounded to the same number of digits than the values picked from the table.

Table 17 – Relationship between material groups and classifications

Material group I	$600 \leq \text{CTI}$
Material group II	$400 \leq \text{CTI} < 600$
Material group IIIa	$175 \leq \text{CTI} < 400$
Material group IIIb	$100 \leq \text{CTI} < 175$
Relationship between material groups and classifications are according to IEC 60112 (CTI values, using solution A).	

Table 18 – Fall distances for impact requirements

Height of fall mm	Parts of enclosures to be subjected to the impacts	
	Ordinary accessory	Other accessories
100	A and B	A and B
150	C	C
200	D	D
<p>A: parts on the front surface, including parts which are recessed.</p> <p>B: parts which do not project more than 15 mm from the mounting surface (distance from the wall) after mounting as in normal use, with the exception of the above parts A.</p> <p>C: parts which project more than 15 mm and not more than 25 mm from the mounting surface (distance from the wall) after mounting as in normal use, with the exception of the above parts A.</p> <p>D: parts which project more than 25 mm from the mounting surface (distance from the wall) after mounting as in normal use, with the exception of the above parts A.</p>		

Table 19 – Test conductors for rated load current test

Test current [A]		Cross section	
Greater than	Less or equal	[mm ²]	AWG/MCM
0	8	1,0	18
8	12	1,5	16
12	15	2,5	14
15	20	2,5	12
20	25	4,0	10
25	32	6,0	10
32	50	10	8
50	65	16	6
65	85	25	4
85	100	35	3
100	115	35	2
115	130	50	1
130	150	50	0
150	175	70	00
175	200	95	000
200	225	95	0000
225	250	120	250
250	275	150	300
275	300	185	350
300	350	185	400
350	400	240	500

NOTE If other standardized cross-sections are used in specific countries, the next closest cross-section should be used for testing.

Table 20 – Current factor k for overload behaviour

Protective device	Trip current factor k
Circuit breaker	1,45
Fuse	1,6

NOTE 1 If the type of protective device (breaker or fuse) is not specified by the manufacturer, the test is performed with the higher k factor.

NOTE 2 For countries using other values, these values should be declared on the SPD's data sheet according to 7.1.1 c7).

NOTE 3 National condition for Japan: k is 1,25 for circuit-breaker and 1,5 for fuse.

NOTE 4 National condition for North America: k is under consideration.

Table 21 – Tolerances for proportional surge currents

Test classification	Proportional currents and tolerances
Test class I	$I_{imp(1)} = I_{imp(2)} = I_{imp(N)} = I_{Total(imp)} / N$ 10 % $Q_{(1)} = Q_{(2)} = Q_{(N)} = Q_{Total} / N$ -10/+20 % $W/R_{(1)} = W/R_{(2)} = W/R_{(N)} = W/R_{Total} / N^2$ -10/+45 %
Test class II	$I_{8/20(1)} = I_{8/20(2)} = I_{8/20(N)} = I_{Total(8/20)} / N$ ± 10%

Table B.1 – TOV test values for systems complying with IEC 60364 series

Application	TOV test parameters		
SPDs connected to:	For $t_T=5$ s (LV-system faults in consumer installation) (requirement to 7.2.8.1 and test 8.3.8.1)	For $t_T=120$ min (LV-system faults in distribution system and loss of neutral (requirement to 7.2.8.1 and test 8.3.8.1)	For $t_T=200$ ms (HV-system faults) (requirement to 7.2.8.2 and test 8.3.8.2)
	Withstand mode required	Withstand or safe failure mode acceptable	Withstand or safe failure mode acceptable
	TOV test values U_T (V)		
TN-systems			
Connected L-(PE)N or L-N	$1,32 \times U_{REF}$	$\sqrt{3} \times U_{REF}$	
Connected N-PE			
Connected L-L			
TT-systems			
Connected L-PE	$\sqrt{3} \times U_{REF}$	$1,32 \times U_{REF}$	$1\ 200 + U_{REF}$
Connected L-N	$1,32 \times U_{REF}$	$\sqrt{3} \times U_{REF}$	
Connected N-PE			1 200
Connected L-L			
IT-systems			
Connected L-PE			$1\ 200 + U_{REF}$
Connected L-N	$1,32 \times U_{REF}$	$\sqrt{3} \times U_{REF}$	
Connected N-PE			$1\ 200 + U_{REF}$
Connected L-L			
U_{REF}	reference test voltage used for testing and taking into account the maximum voltage regulation of the power system (see Annex A).		
U_0	in TN- and TT-systems: nominal a.c. r.m.s. line voltage to earth; in IT-systems: nominal a.c. voltage between line conductor and neutral conductor or midpoint conductor, as appropriate (see 442.1.2 of IEC 60364-4-44:2007).		
$1,32 \times$	U_{REF} equals $1,45 \times U_0$ in case the voltage regulation does not exceed +10 % (see 442.5 of IEC 60364-4-44:2007).		
NOTE As voltage regulation exceeds 10 % in some countries, only U_{REF} is used in this standard for general applicability. Further information on voltage regulation can be found in IEC 60038.			

Table B.3 – TOV test parameters for Japanese systems

Application	TOV test parameters			
	LV system faults	HV system faults		
SPDs connected to:	for $t_T=120$ min	Not specified duration	for $t_T=2$ s	for $t_T=1$ s
	(LV-system faults in distribution system and loss of neutral (requirement to 7.2.8.1 and test 8.3.8.1))	Withstand or safe failure mode acceptable		
	TOV test values U_T [V]			
TN systems				
Connected L-N(PE) or L-N	$\sqrt{3} \times U_{REF}$			
Connected N-PE				
Connected L-L				
TT systems				
Connected L-PE	$\sqrt{3} \times U_{REF}$	$150 + U_{REF}$	$300 + U_{REF}$	$600 + U_{REF}$
Connected L-N	$\sqrt{3} \times U_{REF}$			
Connected N-PE		150	300	600
Connected L-L				
IT systems				
Connected L-PE				$1\ 200 + U_{REF}$
Connected L-N	$\sqrt{3} \times U_{REF}$			
Connected N-PE				$1\ 200 + U_{REF}$
Connected L-L				
U_{REF}	reference test voltage used for testing and taking into account the maximum voltage regulation of the power system (see Annex A).			
NOTE 1 These values are required by ministerial ordinance of technical standards for electrical facilities.				
NOTE 2 As voltage regulation exceeds 10 % in some countries, U_{REF} is used in this standard only for general applicability. Further information on voltage regulation can be found in IEC 60038.				

Table G.1 – Temperature-rise limits

Parts of SPD	Temperature rise K
Built-in components ^a	In accordance with the relevant product standard requirements for the individual components or, in accordance with the component manufacturer's instructions ^f , taking into consideration the temperature in the SPD
Terminals for external insulated conductors	70 ^b
Busbars and conductors, plug-in contacts of removable or withdrawable parts which connect to busbars	Limited by: <ul style="list-style-type: none"> – mechanical strength of conducting material ^g; – possible effect on adjacent equipment; – permissible temperature limit of the insulating materials in contact with the conductor; – effect of the temperature of the conductor on the apparatus connected to it; – for plug-in contacts, nature and surface treatment of the contact material.
Manual operating means: <ul style="list-style-type: none"> – of metal – of insulating material 	<p style="text-align: right;">15 ^c</p> <p style="text-align: right;">25 ^c</p>
Accessible external enclosures and covers: <ul style="list-style-type: none"> – metal surfaces – insulating surfaces 	<p style="text-align: right;">30 ^d</p> <p style="text-align: right;">40 ^d</p>
Discrete arrangements of plug and socket-type connections	Determined by the limit for those components of the related equipment of which they form part ^e
<p>^a The term "built-in components" means:</p> <ul style="list-style-type: none"> – conventional switchgear and controlgear; – electronic sub-assemblies (e.g. rectifier bridge, printed circuit); – parts of the equipment (e.g. regulator, stabilized power supply unit, operational amplifier). <p>^b An SPD used or tested under installation conditions may have connections, the type, nature and disposition of which will not be the same as those adopted for the test, and a different temperature rise of terminals may result. Where the terminals of the built-in component are also the terminals for external insulated conductors, the lower of the corresponding temperature-rise limits shall be applied.</p> <p>^c Manual operating means within SPDs which are only accessible after the SPD has been opened, for example draw-out handles which are operated infrequently, are allowed to assume a 25 K increase on these temperature-rise limits.</p> <p>^d Unless otherwise specified, in the case of covers and enclosures, which are accessible but need not be touched during normal operation, a 10 K increase on these temperature-rise limits is permissible.</p> <p>^e This allows a degree of flexibility in respect of equipment (e.g. electronic devices) which is subject to temperature-rise limits different from those normally associated with switchgear and controlgear.</p> <p>^f For temperature-rise tests according to 8.6.1.1, the temperature-rise limits shall be specified by the manufacturer of the SPD.</p> <p>^g Assuming all other criteria listed are met, a maximum temperature rise of 105 K for bare copper busbars and conductors shall not be exceeded. The 105 K relates to the temperature above which annealing of copper is likely to occur.</p>	

List of test equipment used:

A completed list of used test equipment shall be provided in the Test Reports when a Customer's Testing Facility according to CTF stage 1 or CTF stage 2 procedure has been used.

Note: This page may be removed when CTF stage 1 or CTF stage 2 are not used. See also clause 4.8 in OD 2020 for more details.

Clause	Measurement / testing	Testing / measuring equipment / material used, (Equipment ID)	Range used	Last Calibration date	Calibration due date
/	/	/	/	/	/
/	/	/	/	/	/
/	/	/	/	/	/
/	/	/	/	/	/
/	/	/	/	/	/
/	/	/	/	/	/
/	/	/	/	/	/
/	/	/	/	/	/
/	/	/	/	/	/
/	/	/	/	/	/
/	/	/	/	/	/
/	/	/	/	/	/
/	/	/	/	/	/
/	/	/	/	/	/
/	/	/	/	/	/

	TABLE: Critical components information				P
Object / part No.	Manufacturer/ trademark	Type / model	Technical data	Standard	Mark(s) of conformity¹⁾
Plastic housing	GUANGDONG HTASO NEW MATERIALS TECHNOLOGY CO.,LTD	PA6	Flame Class:HB	IEC60695-11-10	UL E321019
MOV	Changzhou Chuangjie lighting protection Co.,Ltd.	CJV 34S621K	In:20kA I _{max} :40kA	IEC 61643-331:2017	TUV R 50443356
Low temperature solder	Zhejaing Qiangli holding co.,Ltd	2.00mm 145°C	2.00mm 145°C	IEC61643-11	Test with SPD
Micro Switch	Cixi Kefa Electronics co.,Ltd	KF	/	IEC61643-11	Test with SPD

Annex 1

Class I SPDs, 8/20 current impulses oscillograms with I_{imp}
Sample No.: 23100824A20 L3 to PE (Positive polarity)

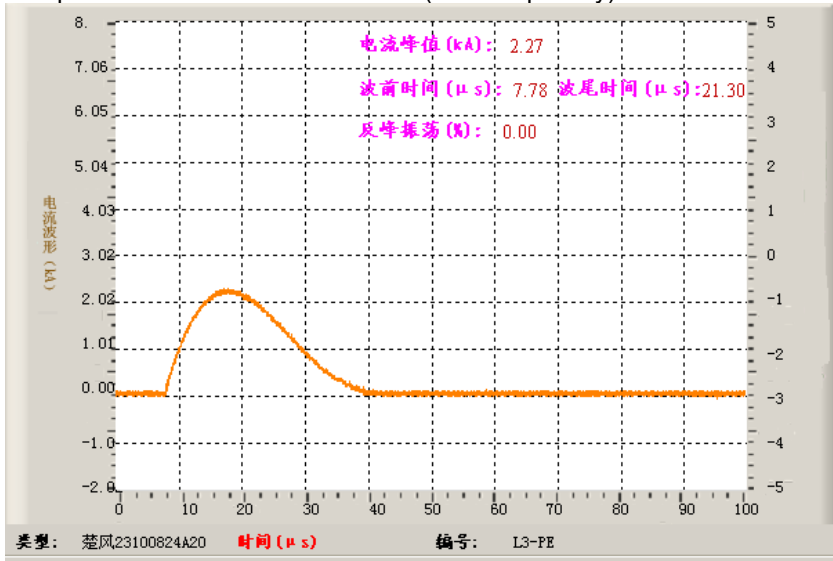

Class II SPDs, 8/20 current impulses oscillograms with I_n
Sample No.: 23100824A07 L1 to PE (Positive polarity)

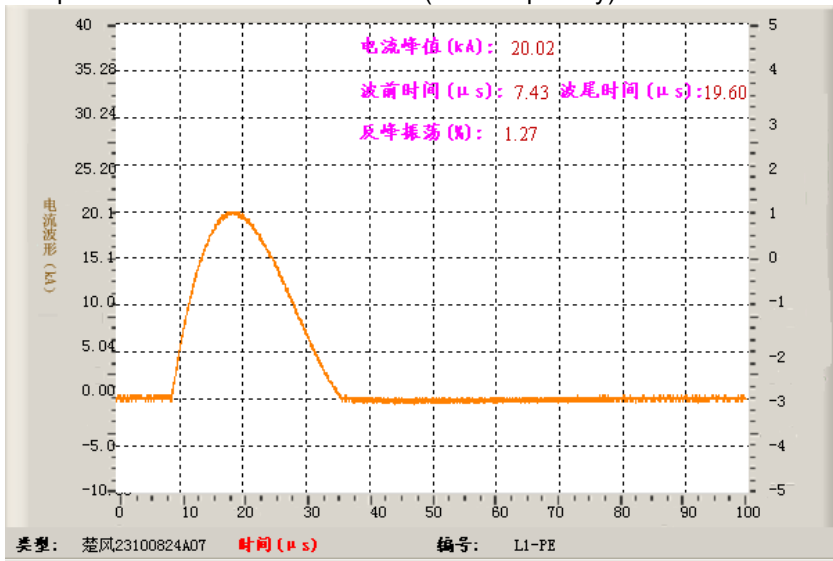

Annex 2:

Current and voltage oscillogram with I_{imp}
Sample No.:23100824A20 L3 to PE

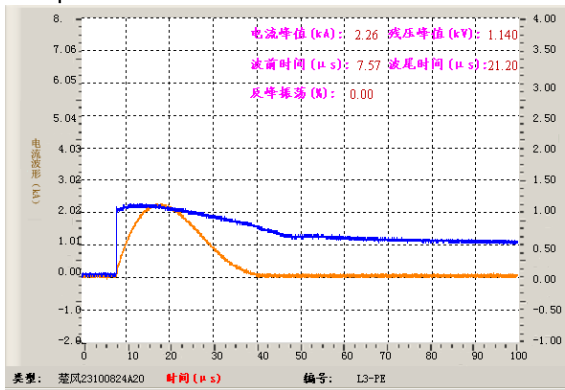

$I_{imp}=2.26kA$

$U_{res}=1.14kV$

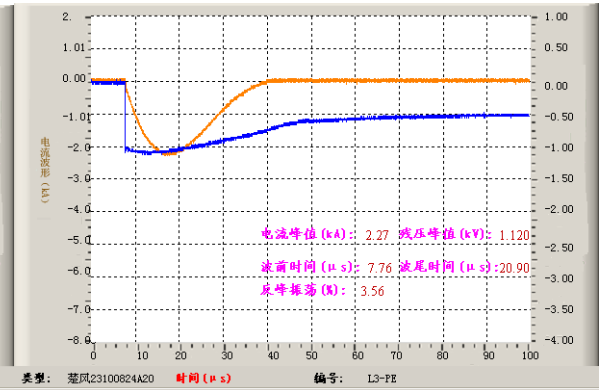

$I_{imp}=-2.27kA$

$U_{res}=-1.12kV$

Current and voltage oscillogram with I_n
Sample No.:23100824A01 L1 to PE

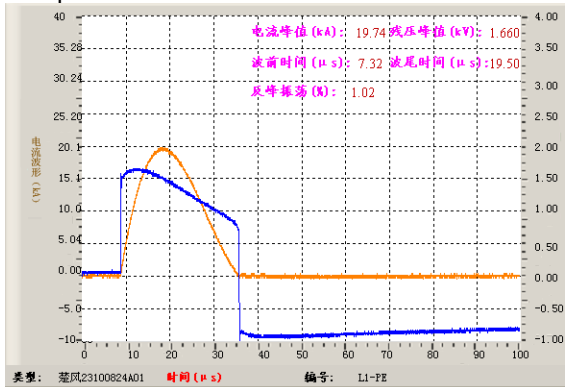

$I_n=19.74kA$

$U_{res}=1.66kV$

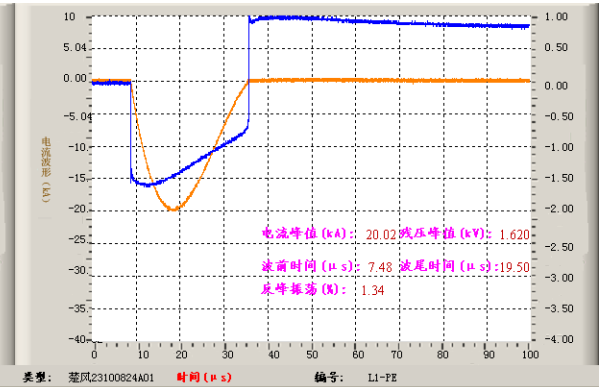

$I_n=-20.02kA$

$U_{res}=-1.62kV$

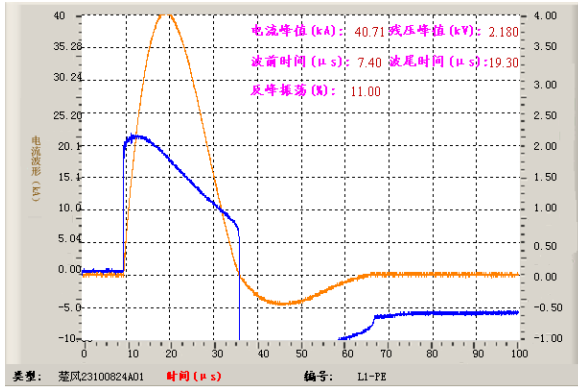

$I_{max}=40.71kA$

$U_{res}=2.18kV$

Annex 3:

Crest values – discharge current versus residual voltage diagram to I_{imp}

Sample No.	23100824A16(L1 to PE)	23100824A20(L3 to PE)	23100824A21(N to PE)
20.0kA (Positive polarity)	1.10kV	1.14kV	1.12kV
20.0kA (Negative polarity)	1.06kV	1.12kV	1.08kV

Crest values – discharge current versus residual voltage diagram to I_n

Sample No.	23100824A01(L1 to PE)	23100824A12(L2 to PE)	23100824A14(N to PE)
20.0kA (Positive polarity)	1.66kV	1.60kV	1.64kV
20.0kA (Negative polarity)	1.62kV	1.58kV	1.60kV

-End of the report-

ATTACHMENT 1

Equipment list

Page 1 of 2

Report No.: CN23930P 001

Product: Surge Protector(Surge Protective Device)
Type Designation: HNS3-40,HNS3R-40, HNS1-40,HNS1R-40
HNS3L-40,HNS3RL-40,HNS1L-40,HNS1RL-40

Test Equipment list					
Instrument Number	Instrument Name	Technical Parameters	Model Type	Last Cal. Date	Next Cal. Date
A-FLTLZ-01	Test thrust force	5N	AG-11A	2023.07.14	2024.07.13
A-FLLDQ-01	Proof tracking tester	/	AG5101B	2022.11.23	2023.11.22
A-FLYKC-01	Vernier caliper	/	/	2022.08.23	2024.08.22
A-FLSYZ-01	standard testing finger forelock probe	/	/	2022.12.08	2023.12.07
A-FLWYB-01	Digital multimeter	/	86C	2023.03.14	2024.03.13
A-FLTPY-01	Electronic balance	/	UTP313	2023.08.29	2024.08.28
A-FLBCC-01	Mechanical impact device	/	AG1100K	2022.11.23	2023.11.22
A-FLSBQ-06	Digital oscilloscope	500M	DPO4054B	2023.03.14	2024.03.13
A-FLCJF-01	Impulse current system	≤80kA	CI-80	2023.03.27	2024.03.26
A-FLRWD-01	Thermal stability tester	0~10A	TTS2-10	2022.11.23	2023.11.22
A-FLQYY-02	Ball pressure tester	/	JQY	2023.08.14	2024.08.13
A-FLSRX-01	High-low temperature test chamber	-70°C-150°C	MHX-1000NK	2023.03.10	2024.03.09
A-DYNY-05	Withstand voltage tester	/	5051A	2023.03.20	2024.03.19
A-DYJYD-05	Insulation Resistance Tester	/	3007A	2023.03.14	2024.03.13
B-FLTYQ-02	Induction regulator	0V-650V	TSA-30	/	/
A-FLWYB-06	Digital multimeter	/	34461A	2023.03.20	2024.03.19
A-FLDDL-01	Digital conductivity meter	/	DDSJ-308F	2023.08.22	2024.08.21
A-FLZRS-01	Glow-wire testing instrument	/	AG5113B	2022.11.23	2023.11.22
A-FLZDJ-01	Illuminometer	/	TES1332A	2022.12.10	2023.12.09
B-FLDLT-01	Short-circuit additional test	1200V/20A	/	/	/

ATTACHMENT 1

Equipment list

Page 2 of 2

Report No.: CN23930P 001

Product: Surge Protector(Surge Protective Device)
Type Designation: HNS3-40,HNS3R-40, HNS1-40,HNS1R-40
HNS3L-40,HNS3RL-40,HNS1L-40,HNS1RL-40

	rig	255V/300A			
A-FLWSD-01	Temperature and humidity instrument	/	VC230	2023.09.26	2024.09.25
A-FLXWJ-01	Microscope	/	ZW-H2100	2023.09.23	2024.09.22
A-FLWSD-03	Temperature and humidity instrument	/	VC230	2023.09.26	2024.09.25
A-FLDLQ-01	Current clamp table	/	FL307	2023.03.21	2024.03.20
A-FLTOV-02	Low pressure TOV test bench	/	/	2023.03.27	2024.03.26
A-FLNJQ-02	Digital torque	/	SNS-8	2022.12.05	2023.12.04
B-FLZLY-01	Dc power supply	150V	/	/	/
A-FLDMB-01	Second chronograph	PC2000A	/	2023.07.09	2024.07.08
A-FLTLZ-02	Test thrust force	NK-300	/	2023.08.21	2024.08.20
A-DYWSD-15	Temperature and humidity instrument	UX100-003	/	2023.03.20	2024.03.19

Product: Surge Protector(Surge Protective Device)
Type Designation: HNS3-40,HNS3R-40, HNS1-40,HNS1R-40
HNS3L-40,HNS3RL-40,HNS1L-40,HNS1RL-40



Figure 1



Figure 2

Product: Surge Protector(Surge Protective Device)
Type Designation: HNS3-40,HNS3R-40, HNS1-40,HNS1R-40
HNS3L-40,HNS3RL-40,HNS1L-40,HNS1RL-40



Figure 3

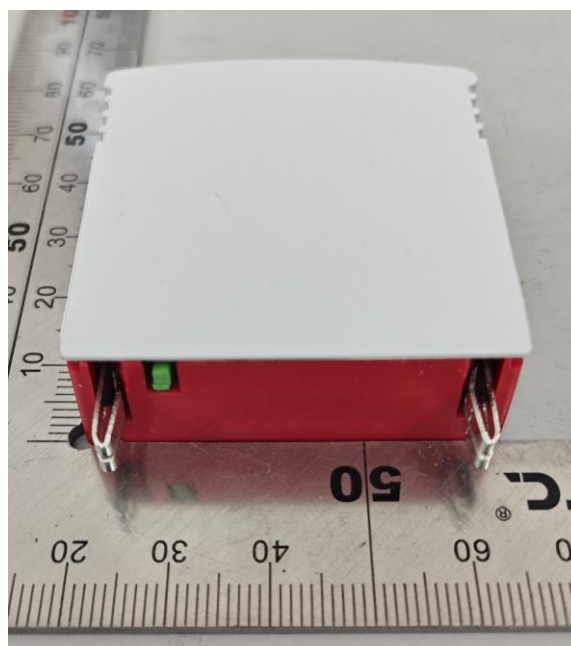

Figure 4

Product: Surge Protector(Surge Protective Device)
Type Designation: HNS3-40,HNS3R-40, HNS1-40,HNS1R-40
HNS3L-40,HNS3RL-40,HNS1L-40,HNS1RL-40



Figure 5

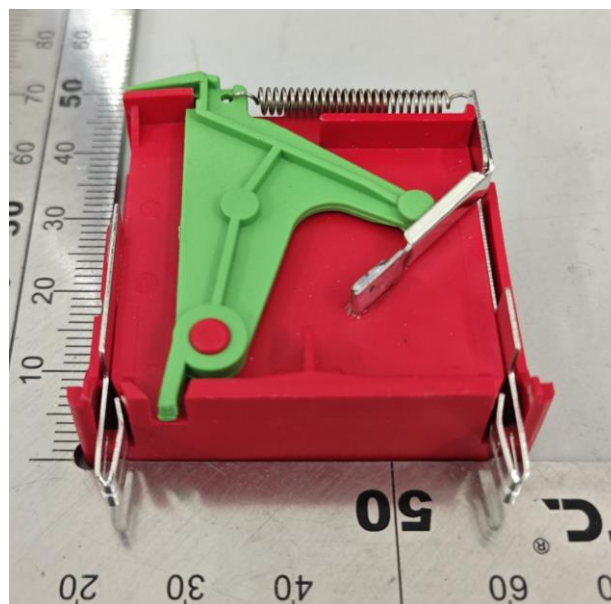

Figure 6

Product: Surge Protector(Surge Protective Device)
Type Designation: HNS3-40,HNS3R-40, HNS1-40,HNS1R-40
HNS3L-40,HNS3RL-40,HNS1L-40,HNS1RL-40



Figure 7

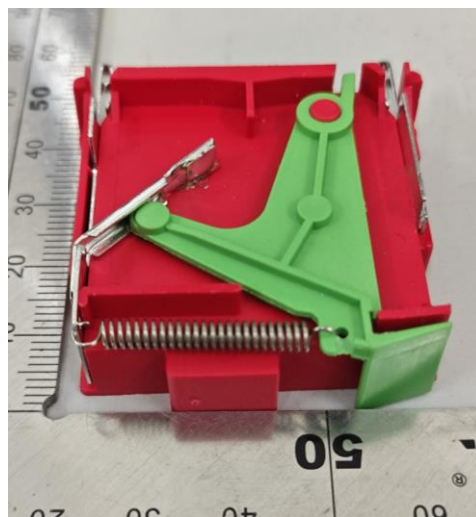

Figure 8

Product: Surge Protector(Surge Protective Device)
Type Designation: HNS3-40,HNS3R-40, HNS1-40,HNS1R-40
HNS3L-40,HNS3RL-40,HNS1L-40,HNS1RL-40

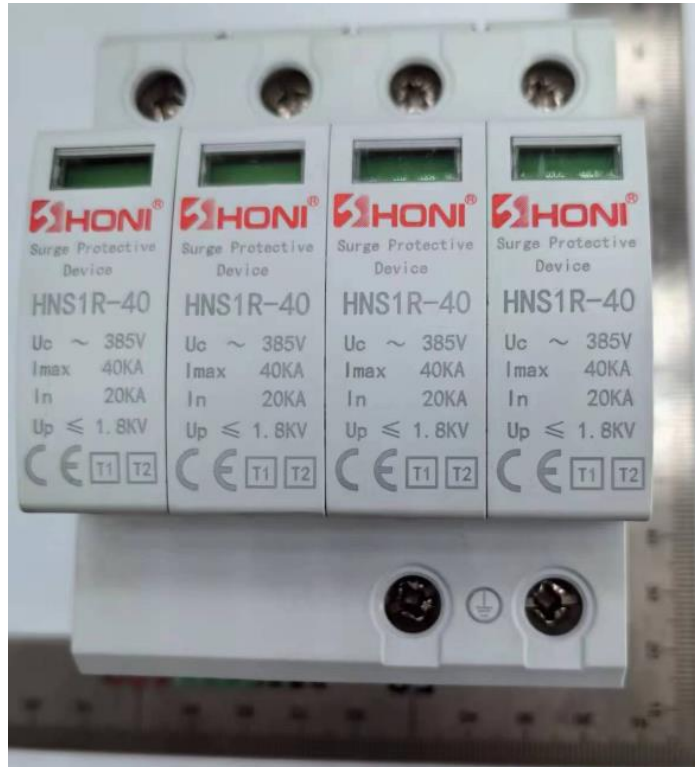

Figure 9



Figure 10

Product: Surge Protector(Surge Protective Device)
Type Designation: HNS3-40,HNS3R-40, HNS1-40,HNS1R-40
HNS3L-40,HNS3RL-40,HNS1L-40,HNS1RL-40



Figure 11



Figure 12

Product: Surge Protector(Surge Protective Device)
Type Designation: HNS3-40,HNS3R-40, HNS1-40,HNS1R-40
HNS3L-40,HNS3RL-40,HNS1L-40,HNS1RL-40



Figure 13



Figure 14

Product: Surge Protector(Surge Protective Device)
Type Designation: HNS3-40,HNS3R-40, HNS1-40,HNS1R-40
HNS3L-40,HNS3RL-40,HNS1L-40,HNS1RL-40



Figure 15



Figure 16

Product: Surge Protector(Surge Protective Device)
Type Designation: HNS3-40,HNS3R-40, HNS1-40,HNS1R-40
HNS3L-40,HNS3RL-40,HNS1L-40,HNS1RL-40



Figure 17

--- END ---

IEC61643_11C - ATTACHMENT			
Clause	Requirement + Test	Result - Remark	Verdict
ATTACHMENT TO TEST REPORT IEC 61643_11C EUROPEAN GROUP DIFFERENCES AND NATIONAL DIFFERENCES Low-voltage surge protective devices- Part 11: Surge protective devices connected to low-voltage power systems – Requirements and test methods			
Differences according to..... : EN 61643-11:2012			
TRF template used..... : IECEE OD-2020-F2:2020, Ed. 1.1			
Attachment Form No. : EU_GD_IEC61643_11C			
Attachment Originator..... : OVE			
Master Attachment : Date 2021-10-07			
Copyright © 2021 IEC System for Conformity Testing and Certification of Electrical Equipment (IECEE), Geneva, Switzerland. All rights reserved.			
CENELEC COMMON MODIFICATIONS (EN)			
IEC 61643-11 - TEST SEQUENCE 1			
Clause	Requirement - Test	Result - Remark	Verdict
7.1.1/7.1.2	Identification and Marking		
	<u>Markings on the body or permanently attached to</u>		
	a4) The SPD type and discharge parameters for each mode of protection declared by the manufacturer and printed next to each other: <u>For Type 1:</u> "Type 1" and "I _{imp} " and the value in kA, and/or "T1" (T1 in a square) and "I _{imp} " and the value in kA <u>For Type 2:</u> "Type 2" and "I _n " and the value in kA, and/or "T2" (T2 in a square) and "I _n " and the value in kA <u>For Type 3:</u> "Type 3" and "U _{OC} " and the value in kV, and/or "T3" (T3 in a square) and "U _{OC} " and the value in kV	2.25 kA T1 20.00 kA T2	P P N/A
	b14) I _{max} (if declared by the manufacturer)	40kA	P
7.2.2	Residual current I_{PE}		
	This test is not performed on SPDs for connection N-PE only		P
	For all SPDs with a terminal for the protective conductor, the residual current I _{PE} shall be measured when all SPD terminals are connected to a power supply at the reference test voltage (U _{REF}) according to the manufacturer's instructions.		P

IEC61643_11C - ATTACHMENT			
Clause	Requirement + Test	Result - Remark	Verdict
8.3.2	All modes of protection of the SPD shall be connected as for normal use according to the manufacturer's instructions. The line to PE voltage of the supply system shall be adjusted to the reference test voltage U_{REF} .	U_{REF} <u>255</u> V I_{PE} <u>0.37</u> mA	P
7.2.4/8.3.4	Operating duty		
	The SPD shall be capable of withstanding specified discharge currents during application of the maximum continuous operating voltage U_C without unacceptable changes in its characteristics. In addition voltage switching type SPDs or combination type SPDs shall be able to interrupt any follow current up to the short-circuit current rating (I_{scrr}) The test setup shall comply with the circuit diagram given in Figure 7.		P
8.3.4.2.2	SPDs with follow current > 500A: The test sample shall be connected to a power frequency voltage at U_C with a prospective short-circuit current equal to the short circuit current rating I_{scrr} declared by the manufacturer and with a power factor in accordance with Table 8, except for SPDs which are only connected between neutral and protective earth in TT- and/or TN-systems, for which the prospective short-circuit current shall be at least 100A.	_____ kA $\cos \phi =$ _____	N/A
7.3.4/8.4.3	Verification of air clearances and creepage distances		
	The air clearances and creepage distances shall not be smaller than the values indicated in Table 15 and Table 16, whereby Table 16 shall be applied to items 1), 2) and 3) according to Table 15.		P
	Creepage distances in millimetres – r.m.s. voltage – Material group – Pollution 1) Between live parts of different polarity 2) Between live parts and – screws and other means to fasten a covering, having to be detached for mounting the SPD – fastening surfaces (note 2) – screws or other means for fastening the SPD (note 2) – bodies (notes 1 and 2)	<u>385VAC</u> <u>IIIa</u> <u>2</u> required / measured <u>4.0mm / 18.8mm</u> ____ / ____ ____ / ____ ____ / ____ <u>4.0mm / 6.9mm</u>	P P P P N/A N/A N/A P

IEC61643_11C - ATTACHMENT			
Clause	Requirement + Test	Result - Remark	Verdict
	3) Between the metal parts of the disconnecter mechanism and – bodies (note 1) – screws or other means for fastening the SPD Printed wiring material – r.m.s. voltage – Material group – Pollution	____ / ____ ____ / ____ ____ ____ ____ required / measured ____ / ____	P P N/A N/A N/A N/A
	1) Between live parts of different polarity 2) Between live parts and – screws and other means to fasten a covering, having to be detached for mounting the SPD – fastening surfaces (note 2) – screws or other means for fastening the SPD (note 2) – bodies (notes 1 and 2) 3) Between the metal parts of the disconnecter mechanism and – bodies (note 1) – screws or other means for fastening the SPD	____ / ____ ____ / ____ ____ / ____ ____ / ____ ____ / ____ ____ / ____	N/A N/A N/A N/A N/A N/A
	NOTE 1 – Definition see 8.3.6 a) NOTE 2 – If clearances between live parts of the device and the metallic screen or the surface on which the SPD is mounted are dependent on the design of the SPD only and cannot be reduced when the SPD is mounted in the least favourable position (even in a metallic enclosure), the values of lines 1 are sufficient.		N/A
7.2.5.4	Status indicator		
	The manufacturer shall provide information about the function of the indicator and the actions to be taken after change of status indication.		P

IEC61643_11C - ATTACHMENT			
Clause	Requirement + Test	Result - Remark	Verdict
	Crest values – discharge current versus residual voltage diagram to I_n or I_{imp}	see Annex 3	P
	The residual voltage used for determining the measured limiting voltage is the highest voltage value corresponding to the range of currents for: <ul style="list-style-type: none"> class I: up to I_{imp} class II: up to I_n 	Class I: <u>1.14kV</u> Class II: <u>1.66kV</u>	P
	The value for determining U_{max} is the highest residual voltage measured at surge currents up to I_n , I_{max} or I_{imp} , as applicable depending on the SPD test class.	2.18kV	P
7.5.1.2	Overload behaviour		
	If an external maximum overcurrent protection is specified by the manufacturer, the SPD shall be loaded for 1 h with a current equal to 1,6 times the rated current of that maximum overcurrent protection.		N/A
8.3.5.3	a) Test at the declared short-circuit current rating		
	The test is carried out twice with U_{REF} applied once at (45 ± 5) electrical degrees and once at (90 ± 5) electrical degrees after the zero crossing of the voltage.		P
8.3.5.3.2	Additional test for SPD's failure mode simulation		
	For this test any electronic indicator circuitry may be disconnected.		N/A
	New samples shall be used and fitted as in normal use, acc. to the manufacturer's instructions and connected with conductors of the maximum cross section acc. to 8.4.2. The maximum length of the cables connection the sample shall be of 0,5 m each.		P
	External disconnectors, if recommended by the manufacturer, shall be used.	—	N/A
	The test sample shall be connected to a power frequency voltage source at the following conditioning voltages: <ul style="list-style-type: none"> SPDs rated U_C up to 440V, apply a voltage equal to $1200 V_{rms}^{+5/-0\%}$ SPDs with U_C rated above 440V, apply a voltage equal to 3 times $U_C^{+5/-0\%}$ 	<u>1200 V</u>	P N/A
	For all types of SPDs with U_C up to 180V, the conditioning voltage may be reduced to 600V if for voltage switching type SPDs and for combination type SPDs, any voltage switching components operate at this voltage.		N/A

IEC61643_11C - ATTACHMENT			
Clause	Requirement + Test	Result - Remark	Verdict
	The conditioning voltage is applied for a duration of 5 s $+5/-0\%$. The prospective short-circuit current of this power source for conditioning shall be adjusted to a value between 1 A and 20 A _{rms} $+5/-0\%$, as provided by the manufacturer according to 7.1.1 d5).	1 A	P
	Following the application of the conditioning voltage equal to U _{REF} $+0/-5\%$ with a short-circuit current capability as given below, shall be applied to the sample for a period of 5 min $+5/-0\%$ or for at least 0,5 s after interruption of the current by an internal or external disconnecter.		P
	The transition from conditioning voltage application to U _{REF} application shall be performed without interruption. The current flow through the SPD shall be monitored. An appropriate test circuit and timing diagram is shown in Figure 12 and Figure 13.		P
	The prospective short-circuit current of the power source at U _{REF} shall have a tolerance of $+5/-0\%$ at the location where the SPD is connected. The power factor of the power source shall comply with Table 8.		P
	Each of the following tests shall be performed on a new set of three preconditioned samples as above at U _{REF} with a short-circuit current of 100A, 500A and 1000A, respectively, unless these values exceed the declared short-circuit rating of the SPD.	100 A	P
	A further test shall be performed on three preconditioned samples as above and at U _{REF} with a prospective short-circuit current equal to the manufacturer's declared short-circuit current rating. For this test, the time interval between the completion of the conditioning test and the application of U _{REF} shall be as short as possible and shall not exceed 100 ms.	The current through the sample during the application of U _{REF} after conditioning does not exceed <u>0.14mA</u>	N/A

IEC61643_11C - ATTACHMENT			
Clause	Requirement + Test	Result - Remark	Verdict
	<p>If all measurements of the test on the first set of samples (100A test set up):</p> <ul style="list-style-type: none"> • either show a disconnection within 5s during the application of the conditioning voltage <p>or</p> <ul style="list-style-type: none"> • the current through the sample during the application of U_{REF} after conditioning does not exceed a value of 1mA <p>or</p> <ul style="list-style-type: none"> • the current through the sample during the application or U_{REF} after conditioning does not exceed the initial value determined at U_{REF} before the test by more than 20% <p>no further test is performed</p>		N/A
	Pass criteria		
	For this test any damage to electronic indicator circuitry during the conditioning test is not regarded as a failure.		N/A
C	No mechanical damage		P
I	SPDs having an IP degree \geq IP 2X – no live parts accessible with standardised test finger applied with a force of 5 N, except the ones which are accessible when the SPD is fitted as in normal use.		P
M	There shall be no explosion or other hazard to either personnel or the facility		P
N	There shall be no flashover to the metallic screen and the 6 A gL/gG fuse connecting the screen shall not operate during the test.		P
	<p>Additional pass criteria except for:</p> <ul style="list-style-type: none"> • short circuiting type SPDs • SPDs where the current is interrupted or no significant current flows during the application of U_{REF}. <p>where no disconnection occurs.</p>	SPDs where the current is interrupted during the application of U_{REF} where no disconnection occurs.	P
H	Disconnection shall be provided by one or more internal or external disconnectors. Their correct indication shall be checked.		N/A

IEC61643_11C - ATTACHMENT			
Clause	Requirement + Test	Result - Remark	Verdict
J	<p>If disconnection occurs during the test, there shall be clear evidence of effective disconnection of the corresponding protective component(s).</p> <p>If internal disconnection occurs, the test sample is connected at U_c and rated frequency for 1 min. The current flow shall not exceed a value of 1 mA.</p>		N/A
	Currents through components connected in parallel to the relevant protective component(s), are disregarded for this measurement.		N/A
	<p>Current through the PE-terminal shall not exceed 1mA</p> <p>If there is more than one possible connection arrangement for normal use, this check shall be performed for all arrangements.</p>		N/A N/A
7.6.1.3	Vibration and shock (informative)		
	<p>Vibration and shock tests shall be performed according to</p> <ul style="list-style-type: none"> EN 60068-2-6 for sinusoidal vibration test EN 60068-2-64 for broadband random vibration test EN 60068-2-27 for shock test 		N/A N/A N/A
ZB-2.2	Transportation		
	Usually SPDs within their packaging are subjected to mechanical stress due to transportation. This should be checked by a vibration and shock test in accordance with EN 60721-3-2		N/A
ZB.2.3	Special applications		
	<p>Special applications of SPDs may require additional vibration and shock tests, on the device itself.</p> <p>Typical values can be found in EN 60721-3-3 and can be as shown in Table ZB.1.</p>		N/A
	Furthermore other applications like railway may require different parameters that are given in corresponding standards or directly from application. For instance required parameters for railway vibration and shock tests are given in EN 61373.		N/A
	During the sinusoidal and random vibration tests (if requested), the sample should be powered under U_c with a short circuit capability of at least 5A.		N/A
ZB.3	Pass criteria		
C	No mechanical damage		N/A

IEC61643_11C - ATTACHMENT			
Clause	Requirement + Test	Result - Remark	Verdict
D	Determination of the measured limiting voltage:		N/A
	according to 8.3.3.1, but only at a crest value corresponding to I_{imp} for test class I		N/A
	according to 8.3.3.1, but only at I_n for test class II		N/A
	according to 8.3.3.3, but only at U_{oc} for test class III		N/A
	SPDs tested acc. to class I and II containing switching components: Front-of-wave sparkover voltage acc. to 8.3.3.2 All measured peak values (5 pos./5 neg.) below U_P		N/A
E	No excessive leakage currents shall occur after the test		N/A
	If there is more than one possible connection arrangement for normal use, this check shall be performed for all arrangements		
	The SPD shall be connected as for normal use according to the manufacturer's instructions to a power supply at the reference test voltage (U_{REF}). The current that flows through each terminal is measured. Its resistive component (measured at the crest of the sine wave) <ul style="list-style-type: none"> • shall not exceed a value of 1 mA or <ul style="list-style-type: none"> • the current shall not have changed by more than 20% compared to the initial value determined at the beginning of the test sequence 		N/A N/A N/A
	Any resettable or rearmable disconnecter shall be switched off and dielectric withstand shall be checked by application of two times U_C or 1000V a.c. whichever is greater. During the test, no flashover, breakdown of insulation or any other manifestation of disruptive discharge shall occur.		N/A N/A

IEC61643_11C - ATTACHMENT			
Clause	Requirement + Test	Result - Remark	Verdict
	<p>For SPD modes connected N-PE only, the current through the PE-terminal shall be measured, whereas the terminals are connected to a power supply at U_c.</p> <p>Its resistive component (measured at the crest of the sine wave)</p> <ul style="list-style-type: none"> shall not exceed a value of 1 mA <p>or</p> <ul style="list-style-type: none"> the current shall not have changed by more than 20% compared to the initial value determined at the beginning of the test sequence 		N/A N/A N/A
G	Internal disconnectors shall not operate during the test and shall be in working order after the test.		N/A
I	SPDs having an IP degree \geq IP 2X – no live parts accessible with standardised test finger applied with a force of 5 N, except the ones which are accessible when the SPD is fitted as in normal use.		N/A

ATTACHMENT to TRF IEC61643_11C			
Clause	Requirement + Test	Result - Remark	Verdict
ATTACHMENT TO TEST REPORT IEC 61643-11:2011 EUROPEAN GROUP DIFFERENCES AND NATIONAL DIFFERENCES (Low-voltage surge protective devices – Part 11: surge protective devices connected to low-voltage power systems – Requirements and test methods)			
Differences according to: EN 61643-11:2012/A11:2018			
TRF template used: IEC EE OD-2020-F2:2022, Ed. 1.2			
Attachment Form No.: EU_GD_IEC61643_11C_II			
Attachment Originator: UL Solutions (Demko)			
Master Attachment: Dated 2023-05-12			
Copyright © 2023 IEC System for Conformity Testing and Certification of Electrical Equipment (IECEE), Geneva, Switzerland. All rights reserved.			
7.5.5	CENELEC COMMON MODIFICATIONS (EN)		
	7.5.5 Portable SPDs classified as pluggable equipment type A		
ZC	Additional requirements for portable SPDs classified as pluggable equipment type A		N/A
	Annex ZC applies to portable SPDs classified as pluggable equipment type A according to EN 62368-1.		N/A
ZC.7.7	Specific requirements for portable SPDs classified as pluggable equipment type A		N/A
	For portable SPDs considered as pluggable equipment type A, the following specific requirements apply.		N/A
	— Every mode of protection provided with an appropriate internal disconnecter(s). No external disconnecters required. All tests passed by the SPD itself.		N/A
	— Live terminals not specifically assigned to a line terminal or to a neutral terminal. All live terminals tested in the same way (due to possible inversion).		N/A
	— No exceptions related to N-PE mode of protection of the main document apply to portable SPDs.		N/A
	— Wherever disconnecter operation is required, it provided by internal disconnecter(s).		N/A

ATTACHMENT to TRF IEC61643_11C			
Clause	Requirement + Test	Result - Remark	Verdict
	— Internal disconnectors dedicated to the SPD function not resettable or replaceable.		N/A
	— The short circuit current rating Isccr not lower than 1 500 A.		N/A
	— All possible protection modes tested, i.e. live to live and live to PE, when applicable.		N/A
	— Voltage limiting components rated to a minimum value of 1,25 times the nominal rated		N/A
	For SPDs with no protection mode connected to PE, no additional requirement applies.		N/A
	For SPDs with a protection mode connected to PE, this protection mode consist of at least one voltage limiting component (e.g. MOV) and one voltage switching component (e.g. GDT) connected in series.		N/A
	Portable multiservice SPDs designed to protect more than one kind of service e.g. power, data, and telecom system, provided with modes of protection referring to a common reference point. NOTE: This common reference point is normally connected to PE or the equipotential bonding system of the fixed installation		N/A
	All clearances and creepage distances, including distances along outer surfaces of components, comply with the requirements for basic insulation of overvoltage category II and pollution degree 2. Compliance is checked by visual inspection and the relevant tests of Clause 8 in conjunction with this Annex ZC.		N/A
ZC.8.3.5.3	Short-circuit current behaviour tests		N/A
	b) Test at low short-circuit current The prospective short-circuit current set to 100 A.		N/A
	Pass criteria Pass criteria C, H, I, J, K, M and N according to Table 4 apply.		N/A
ZC.8.3.5.3.2	Additional test for SPD's failure mode simulation		N/A
	Pass criteria Pass criteria C, H, I, J, M and N according to Table 4 apply.		N/A
ZC.8.3.8	Behaviour under temporary overvoltages (TOVs)		N/A

