

Wenzhou HONI Electric Co., Ltd.

TEST REPORT

SCOPE OF WORK:

EMC report

Model:

HB202B, HB204B

REPORT NUMBER

2506B1062SHA-001

ISSUE DATE

August 6, 2025

DOCUMENT CONTROL NUMBER

TTRF61543_V3

© 2024 Intertek



Report no. 2506B1062SHA-001

Applicant : Wenzhou HONI Electric Co., Ltd.
No.46 Keaisi Road, Xiangyang Industrial Zone, Liushi Town,
Yueqing City, Zhejiang, P.R.China

Manufacturer : Same as applicant

Manufacturing site : Same as applicant

Summary

The equipment complies with the requirements according to the following standard(s) or Specification:
EN IEC 61543:2023+A11:2023/ IEC 61543:2022: Residual current-operated protective devices (RCDs)
for household and similar use-Electromagnetic compatibility

Test Result: Pass

PREPARED BY: **REVIEWED BY:**

David Huang
David Huang
Project Engineer

Star Guo
Star Guo
Reviewer

This report is for the exclusive use of Intertek's Client and is provided pursuant to the agreement between Intertek and its Client. Intertek's responsibility and liability are limited to the terms and conditions of the agreement. Intertek assumes no liability to any party, other than to the Client in accordance with the agreement, for any loss, expense or damage occasioned by the use of this report. Only the Client is authorized to permit copying or distribution of this report and then only in its entirety. Any use of the Intertek name or one of its marks for the sale or advertisement of the tested material, product or service must first be approved in writing by Intertek. The observations and test results in this report are relevant only to the sample tested. This report by itself does not imply that the material, product, or service is or has ever been under an Intertek certification program.

Contents

REVISION HISTORY	5
MEASUREMENT RESULT SUMMARY	6
1 GENERAL INFORMATION	7
1.1 DESCRIPTION OF EQUIPMENT UNDER TEST (EUT)	7
1.2 DESCRIPTION OF TEST FACILITY	8
2 TEST SPECIFICATIONS	9
2.1 STANDARDS	9
2.2 MODE OF OPERATION DURING THE TEST	9
2.3 TEST PERIPHERALS USED	9
2.4 RECORD OF CLIMATIC CONDITIONS	9
2.5 INSTRUMENT LIST	10
2.6 MEASUREMENT UNCERTAINTY	10
EMISSION TEST	12
3 MAINS/LOAD/CONTROL TERMINAL CONTINUOUS DISTURBANCE VOLTAGE	12
3.1 TERMINAL VOLTAGE LIMITS FOR THE FREQUENCY RANGE 150KHZ TO 30MHZ.....	12
3.1.1 <i>Limits for household appliances, electric power tools and similar devices at mains terminals</i>	12
3.1.2 <i>Limits for household appliances and similar devices at additional terminals</i>	13
3.2 BLOCK DIAGRAM OF TEST SETUP	14
3.3 TEST SETUP AND TEST PROCEDURE	15
3.4 TEST PROTOCOL	16
4 MAINS TERMINAL DISCONTINUOUS DISTURBANCE VOLTAGE	23
4.1 BLOCK DIAGRAM OF TEST SETUP	23
4.2 TEST SETUP AND TEST PROCEDURE	23
4.3 TEST PROTOCOL	24
5 CONTINUOUS DISTURBANCE POWER	25
5.1 LIMIT	25
5.1.1 <i>Limits for household and similar appliances</i>	25
5.1.2 <i>Limits for electric tools</i>	25
5.2 BLOCK DIAGRAM AND TEST SETUP	26
5.3 TEST SETUP AND TEST PROCEDURE	26
5.4 TEST PROTOCOL	27
6 RADIATED EMISSION	28
6.1 LIMIT	28
6.2 BLOCK DIAGRAM AND TEST SETUP	28
6.3 TEST PROTOCOL	29
IMMUNITY TEST	32
7 SURGE IMMUNITY TEST	33
7.1 SEVERITY LEVEL AND PERFORMANCE CRITERION	33
7.1.1 <i>Test Level</i>	33
7.1.2 <i>Performance Criterion</i>	33
7.2 BLOCK DIAGRAM OF TEST SETUP	34
7.3 TEST SETUP AND TEST PROCEDURE	34
7.4 TEST PROTOCOL	35
8 CONDUCTED SINE-WAVE FORM VOLTAGES OR CURRENTS	36

- 8.1 SEVERITY LEVEL AND PERFORMANCE CRITERION 36
 - 8.1.1 *Test Level* 36
 - 8.1.2 *Performance Criterion* 36
- 8.2 BLOCK DIAGRAM OF TEST SETUP 37
 - 8.2.1 *Block Diagram for a.c./d.c input power line*..... 37
 - 8.2.2 *Block Diagram for output a.c./d.c. power line or signal/control lines*..... 37
- 8.3 TEST SETUP AND TEST PROCEDURE 38
- 8.4 TEST PROTOCOL 39
- 9 RADIATED MAGNETIC FIELD 40**
 - 9.1 SEVERITY LEVEL AND PERFORMANCE CRITERION 40
 - 9.1.1 *Test Level* 40
 - 9.1.2 *Performance Criterion* 40
 - 9.2 BLOCK DIAGRAM OF TEST SETUP 41
 - 9.3 TEST SETUP AND TEST PROCEDURE 41
 - 9.4 TEST PROTOCOL 42
- 10 ELECTRIC FAST TRANSIENT/BURST IMMUNITY TEST 43**
 - 10.1 SEVERITY LEVEL AND PERFORMANCE CRITERION 43
 - 10.1.1 *Test Level* 43
 - 10.1.2 *Performance Criterion* 43
 - 10.2 BLOCK DIAGRAM OF TEST SETUP 44
 - 10.2.1 *Block Diagram for input a.c./d.c. power line*..... 44
 - 10.2.2 *Block Diagram for output a.c./d.c. power line or signal/control lines*..... 45
 - 10.3 TEST SETUP AND TEST PROCEDURE 46
 - 10.4 TEST PROTOCOL 46
- 11 CONDUCTED COMMON MODE DISTURBANCES IN THE FREQUENCY RANGE LOWER THAN 150 KHZ..... 47**
 - 11.1 SEVERITY LEVEL AND PERFORMANCE CRITERION 47
 - 11.1.1 *Test Level* 47
 - 11.1.2 *Performance Criterion* 47
 - 11.2 BLOCK DIAGRAM OF TEST SETUP 48
 - 11.3 TEST SETUP AND TEST PROCEDURE 48
 - 11.4 TEST PROTOCOL 49
- 12 ELECTROSTATIC DISCHARGE (ESD)..... 50**
 - 12.1 SEVERITY LEVEL AND PERFORMANCE CRITERION 50
 - 12.1.1 *Test Level* 50
 - 12.1.2 *Performance Criterion* 50
 - 12.2 BLOCK DIAGRAM OF TEST SETUP 51
 - 12.3 TEST SETUP AND TEST PROCEDURE 52
 - 12.4 TEST PROTOCOL 52
- 13 VOLTAGE DIPS AND INTERRUPTIONS 53**
 - 13.1 SEVERITY LEVEL AND PERFORMANCE CRITERION 53
 - 13.1.1 *Test level and performance criterion* 53
 - 13.2 TEST SETUP 54
 - 13.3 TEST PROCEDURE 54
 - 13.4 TEST RESULT 55
- APPENDIX I: PHOTOGRAPH OF EQUIPMENT UNDER TEST 56**

Revision History

Report No.	Version	Description	Issued Date
2506B1062SHA-001	Rev. 01	Initial issue of report	August 6, 2025

Measurement Result Summary

	TEST ITEM	TEST RESULT	NOTE
Emission Test ⁽¹⁾	Mains Terminal Continuous Disturbance Voltage	Pass	
	Mains Terminal Discontinuous Disturbance Voltage	NA	
	Continuous Disturbance Power	NA	
	Radiated Emission	Pass	
Immunity Test	Surges	Pass	
	Conducted sine-wave form voltages or currents	Pass	
	Radiated Magnetic Field	Pass	
	Electric Fast Transient /Burst (EFT/B)	Pass	
	Conducted common mode disturbances in the frequency range lower than 150 kHz	Pass	
	Electrostatic Discharge (ESD)	Pass	
	Voltage dips and interruptions	Pass	

Notes: 1: NA =Not Applicable

2: Determination of the test conclusion is based on IEC Guide 115 in consideration of measurement uncertainty.

3: Additions, Deviations and Exclusions from Standards: None.

⁽¹⁾ According to Clause 4 of EN61543, for RCDs without a continuously operating oscillator, emission tests are not required.

1 General Information

1.1 Description of Equipment Under Test (EUT)

Product name : Type B RCCBs

Type/Model : HB202B, HB204B

Description of EUT : The worst data is listed as representative.

Rating : $U_n =$ AC240V (AC230V) for 1P+N, AC415V (AC400V) for 3P+N
 $I_n =$ 16, 20, 25, 32, 40, 50, 63A
 $I_{\Delta n} =$ 30, 100, 300mA, Type B

Brand name : 

Mains lead : 0 m, (un)shielded, (non)detachable

Data cable : 0 m, (un)shielded, (non)detachable

EUT type : Table-top
 Floor standing

Date of test : 2025-04-28 to 2025-04-29

1.2 Description of Test Facility

Report issued by

Name: Intertek Testing Services (Shanghai FTZ) Co., Ltd.
Address: Building No.86, 1198 Qinzhou Road (North), Shanghai 200233,
China
A2LA No.: 3309.02
Telephone: +86 021 61278200

Tests performed in:

Name: Zhejiang Fangyuan Test Group Co., Ltd.
Address: No. 400 Guangqiong Rd., Jiaxing, Zhejiang, CHINA
CNAS No.: L0116
Telephone: +86 0573-82077511

2 Test Specifications

2.1 Standards

EN IEC 61543:2023+A11:2023/ IEC 61543:2022: Residual current-operated protective devices (RCDs) for household and similar use-Electromagnetic compatibility

2.2 Mode of operation during the test

Within this test report, the EUT was tested with full load in emission tests (if applicable). The EUT was tested without load in immunity tests.

2.3 Test Peripherals used

Item No	Description	Band and Model	S/No
1	-	-	-

2.4 Record of Climatic Conditions

Test Item	Temperature (°C)	Relative Humidity (%)	Pressure (Kpa)
Mains Terminal Continuous Disturbance Voltage	23.7	49.2	NA
Radiated Emission	23.9	49.2	NA
Surges	23.9	49.2	NA
Conducted sine-wave form voltages or currents	23.7	48.4	NA
Radiated Magnetic Field	24.2	48.7	NA
Electric Fast Transient /Burst (EFT/B)	23.8	49.4	NA
Conducted common mode disturbances in the frequency range lower than 150 kHz	23.7	48.6	NA
Electrostatic Discharge (ESD)	23.9	48.4	101
Voltage dips and interruptions	23.7	48.6	NA

Notes: NA =Not Applicable

2.5 Instrument List

Test equipment	Model	Internal No.	Cal. Due date
Receiver	ESR7	9618-6DA23A	2025-12-08
LISN	NSLK8126	8610CA12A	2025-07-31
Transient Limiter	CFL9206A	8611CA12A	2025-07-31
Pre-amplifier	310N	8612CA12A	2025-07-31
Receive antenna	VULB 9160	8616CA12A	2025-08-03
3m Semi-anechoic chamber	SAC-3M	8699DA12A	2027-08-17
Residual current meter	IDB-1A	8018CB83B	2025-08-19
Surge generator	EMS61000-5A	8784CA18A	2025-10-16
CDN	SGN-2A	8786DA18A	2026-02-10
Thermohygrograph	testo622	9698CB23B	2025-08-29
CS test system	NSG4070	8618CA12A	2025-07-31
Attenuator	ATN6050	8619CA12A	2025-07-31
CDN	CDN M016	8620CA12A	2025-07-31
Signal generator	N5181A	8601CA12A	2025-07-31
Power meter	4242	8602CA12A	2025-07-31
RF switch	NS4900	8603CA12A	2025-07-31
Power amplifier	AS0102-65	8604CA12A	2025-07-31
Power amplifier	80RF1000-175	8605CA12A	2025-07-31
3m semi-anechoic chamber	SAC-3M	8699DA12A	2027-08-17
DDC	C6021-10	8613CA12A	2025-07-31
Field probe	EP600	8614CA12A	2025-11-04
EFT generator	EMS61000-4A	8848DA19A	2026-02-10
Signal generator	PSG-300A	8688-1CA14A	2025-10-16
Multifunction meter	34461A	8688-4CA14A	2025-11-11
ESD generator	EMS61000-2A	8849DA19A	2026-02-20
Three phase voltage dips system	VDS-1120A	9536DA23A	2025-11-06

2.6 Measurement Uncertainty

Measurement	Frequency	Expanded Uncertainty (k=2) (±)
Conducted emission at mains ports	9kHz ~ 150kHz	3.52 dB
	150kHz ~ 30MHz	3.19 dB
Continuous disturbance voltage at telecom ports	150kHz ~ 30MHz	3.64 dB
Continuous disturbance current at telecom ports	150kHz ~ 30MHz	2.62 dB
Radiated Emissions up to 1 GHz	30MHz ~ 1GHz	4.90 dB
Radiated Emissions above 1 GHz	1GHz ~ 6GHz	5.02 dB
	6GHz ~ 18GHz	5.28 dB
Harmonic current emission	-	3.90%
Voltage fluctuations and flicker	-	10.34%
ESD	-	6.65%
Radiated susceptibility	-	2.38%
EFT test at main terminal	-	11.57%
EFT test at signal/telecom terminal	-	11.62%
Surge test at main terminal	-	11.57%
Injected current test at main terminal	-	1.88 dB
Injected current test at unshielded signal terminal	-	3.41 dB
Voltage dips and interruption	-	6.05%

Emission Test

3 Mains/Load/Control Terminal Continuous Disturbance Voltage

Test result: **Pass**

3.1 Terminal Voltage Limits for the frequency range 150kHz to 30MHz

3.1.1 Limits for household appliances, electric power tools and similar devices at mains terminals

For household appliance

Frequency range (MHz)	Limits dB(μV)	
	Quasi-peak	Average
0.15 ~ 0.5	66 ~ 56 *	59 ~ 46 *
0.5 ~ 5	56	46
5 ~ 30	60	50

Note: 1. * means the limit decreasing linearly with the logarithm of the frequency in the range 0.15MHz to 0.5MHz
 2. If the limit for the measurement with the average detector is met when using a receiver with a quasi-peak detector, the equipment under test shall be deemed to meet both limits and the measurement using the receiver with an average detector need not be carried out.

For electric power tools

Frequency (MHz)	Rated motor power not exceeding 700W		Rated motor power above 700W and not exceeding 1000W		Rated motor power above 1000W	
	dB(μV)		dB(μV)		dB(μV)	
	Quasi-Peak	Average	Quasi-Peak	Average	Quasi-Peak	Average
0.15-0.35	66-59*	59-49*	70-63*	63-53	76-69*	69-59*
0.35-5	59	49	63	53	69	59
5-30	64	54	68	58	74	64

Notes: 1. * means the limit value decreasing linearly with the logarithm of the frequency.
 2. If the limit for the measurement with the average detector is met when using a receiver with a quasi-peak detector, the equipment under test shall be deemed to meet both limits and the measurement using the receiver with an average detector need not be carried out.

3.1.2 Limits for household appliances and similar devices at additional terminals

Frequency range (MHz)	Limits dB(μ V)	
	Quasi-peak	Average
0.15 ~ 0.5	80	70
0.5 ~ 5	74	64
5 ~ 30	74	64
<p>Note: 1. If the limit for the measurement with the average detector is met when using a receiver with a quasi-peak detector, the equipment under test shall be deemed to meet both limits and the measurement using the receiver with an average detector need not be carried out.</p>		

3.2 Block Diagram of Test Setup

At mains terminal

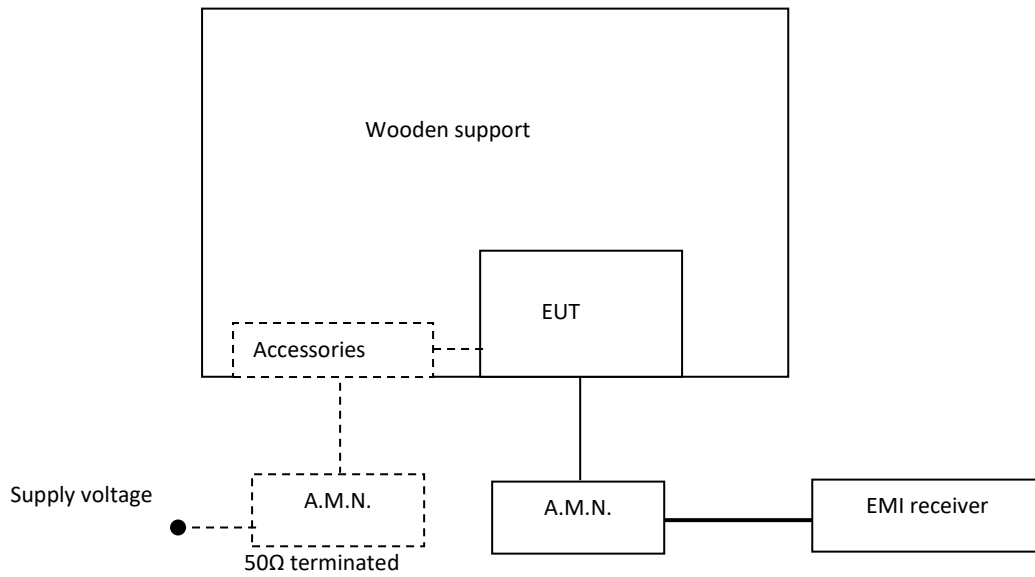

For table top equipment, wooden support is 0.8m height table

For floor standing equipment, wooden support is 0.1m height rack.

At output and control terminals

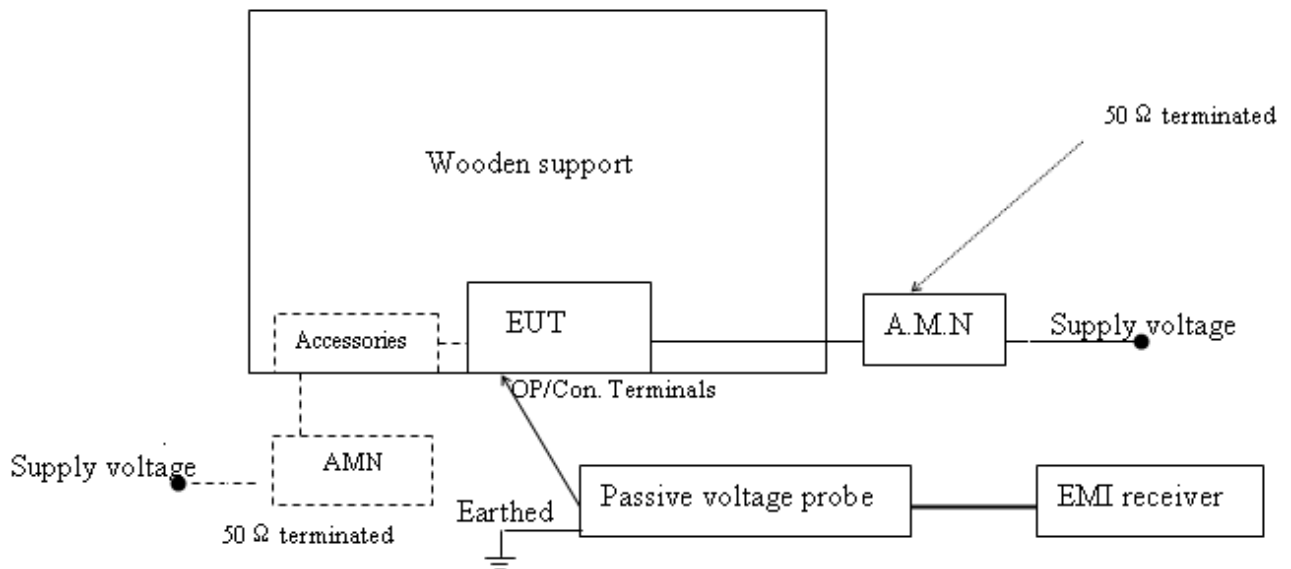

Note:
 ————— : power line
 ————— : signal line
 - - - - - : means the test setup while available

3.3 Test Setup and Test Procedure

Measurement was performed in shielded room, and instruments used were follow EN 55014-1 clause 5.1, 5.2, 5.3 and 5.4 if applicable.

Detailed test procedure and arrangement was follow EN 55014-1 clause 5.2.

Measurement methods and operation conditions of EUT was according to EN 55014-1 clause 7.

Frequency range 150kHz – 30MHz was checked and EMI receiver measurement bandwidth was set to 9kHz.

3.4 Test Protocol

Sample 1:

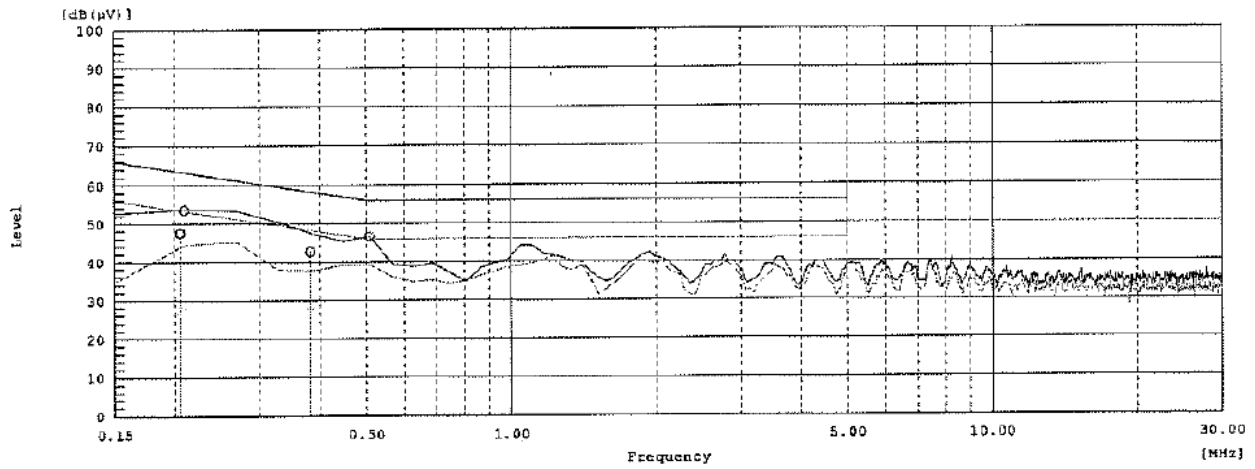

Final Result

--- L1 Phase ---

No.	Frequency [MHz]	Reading QP [dB(µV)]	Reading AV [dB(µV)]	c.f [dB]	Result QP [dB(µV)]	Result AV [dB(µV)]	Limit QP [dB(µV)]	Limit AV [dB(µV)]	Margin QP [dB]	Margin AV [dB]
1	0.20556	37.4	17.2	10.2	47.6	27.4	63.4	53.4	15.6	26.0
2	0.38283	32.5	18.0	10.2	42.7	28.2	58.2	48.2	15.5	20.0

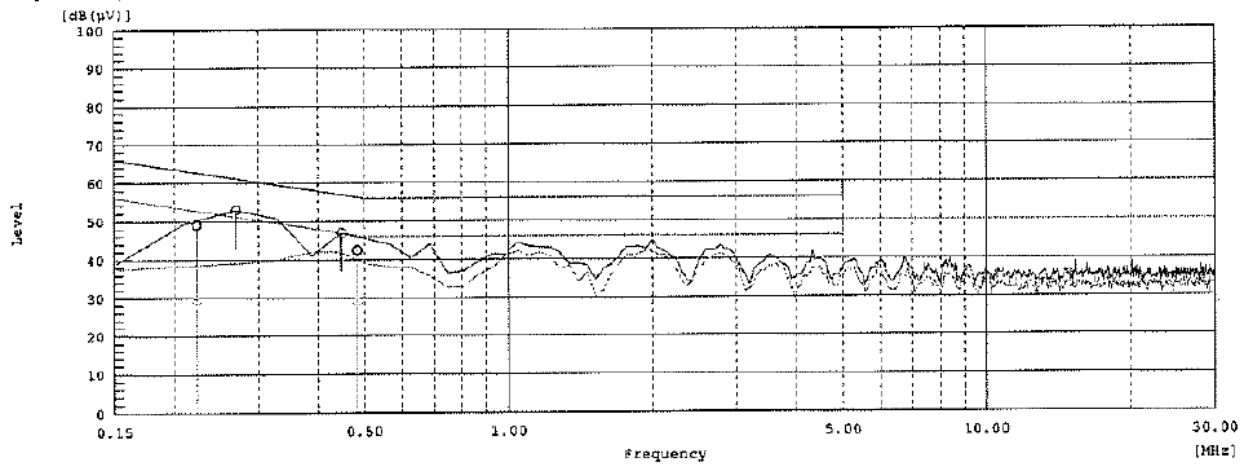

Final Result

--- L2 Phase ---

No.	Frequency [MHz]	Reading QP [dB(µV)]	Reading AV [dB(µV)]	c.f [dB]	Result QP [dB(µV)]	Result AV [dB(µV)]	Limit QP [dB(µV)]	Limit AV [dB(µV)]	Margin QP [dB]	Margin AV [dB]
1	0.22307	38.8	18.6	10.3	49.1	28.9	62.7	52.7	13.6	23.8
2	0.48372	32.1	18.6	10.4	42.5	29.0	56.3	46.3	13.8	17.3

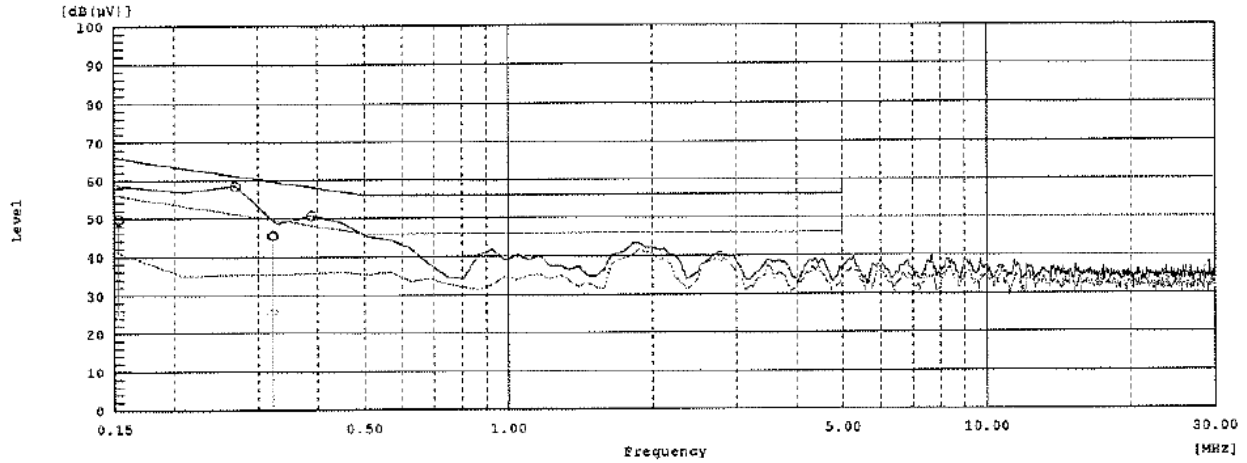

Final Result

--- L3 Phase ---

No.	Frequency [MHz]	Reading QP [dB(µV)]	Reading AV [dB(µV)]	c.f [dB]	Result QP [dB(µV)]	Result AV [dB(µV)]	Limit QP [dB(µV)]	Limit AV [dB(µV)]	Margin QP [dB]	Margin AV [dB]
1	0.15322	39.5	14.8	10.2	49.7	25.0	65.8	55.8	16.1	30.8
2	0.32253	35.1	15.2	10.3	45.4	25.5	59.6	49.6	14.2	24.1

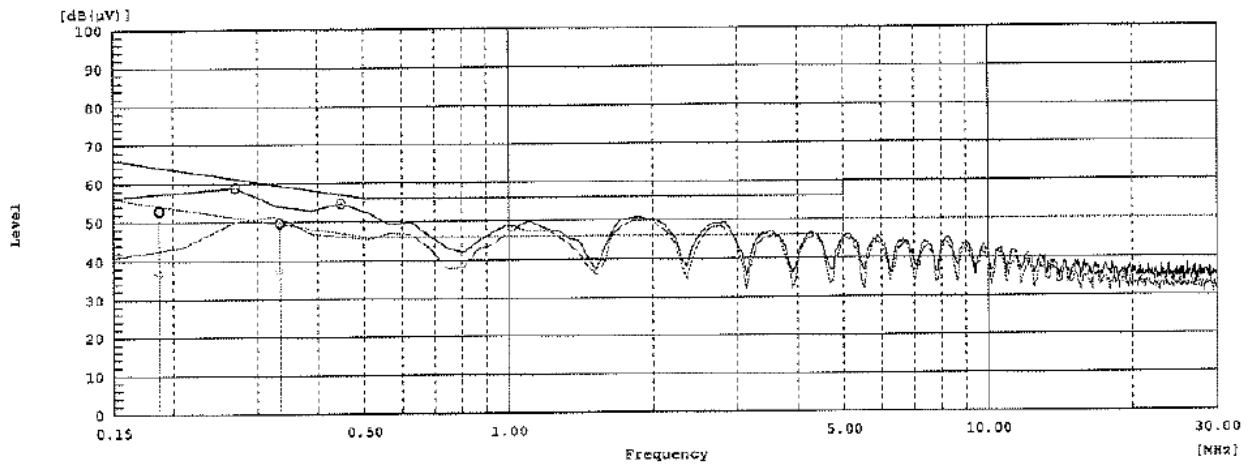

Final Result

--- N Phase ---

No.	Frequency [MHz]	Reading QP [dB(µV)]	Reading AV [dB(µV)]	c.f [dB]	Result QP [dB(µV)]	Result AV [dB(µV)]	Limit QP [dB(µV)]	Limit AV [dB(µV)]	Margin QP [dB]	Margin AV [dB]
1	0.18707	42.8	26.7	10.2	53.0	36.9	64.2	54.2	11.2	17.3
2	0.33388	39.3	27.2	10.3	49.6	37.5	59.4	49.4	9.8	11.9

Sample 2:

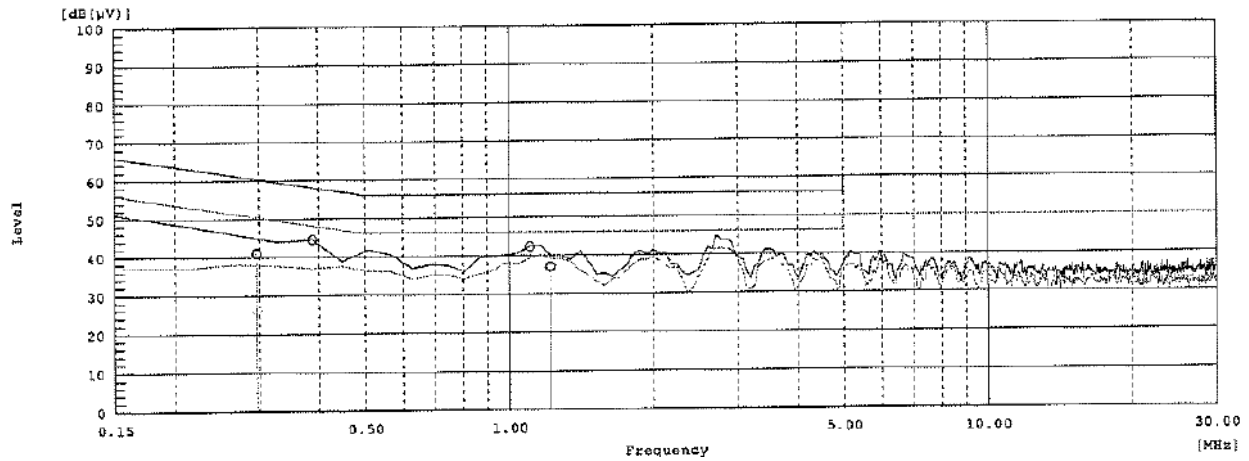

Final Result

--- L1 Phase ---

No.	Frequency [MHz]	Reading QP [dB(µV)]	Reading AV [dB(µV)]	c.f [dB]	Result QP [dB(µV)]	Result AV [dB(µV)]	Limit QP [dB(µV)]	Limit AV [dB(µV)]	Margin QP [dB]	Margin AV [dB]
1	0.296886	30.9	15.9	10.2	41.1	26.1	60.3	50.3	19.2	24.2
2	1.21923	26.7	19.9	10.3	37.0	30.2	56.0	46.0	19.0	15.8

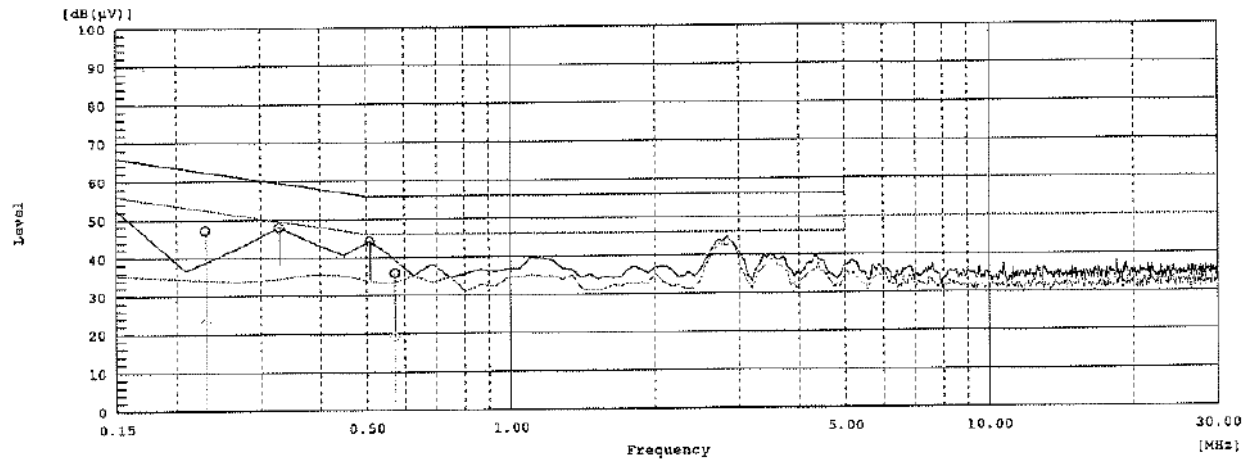

Final Result

--- L2 Phase ---

No.	Frequency [MHz]	Reading QP [dB(µV)]	Reading AV [dB(µV)]	c.f [dB]	Result QP [dB(µV)]	Result AV [dB(µV)]	Limit QP [dB(µV)]	Limit AV [dB(µV)]	Margin QP [dB]	Margin AV [dB]
1	0.2306	36.9	12.8	10.3	47.2	23.1	62.4	52.4	15.2	29.3
2	0.57387	25.4	8.8	10.4	35.8	19.2	56.0	46.0	20.2	26.8

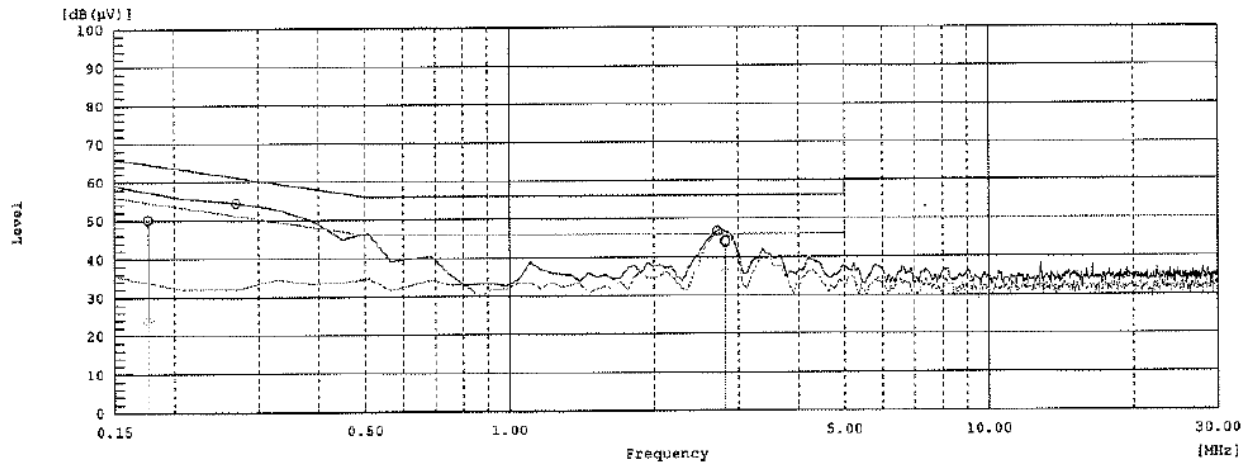

Final Result

--- L3 Phase ---

No.	Frequency [MHz]	Reading QP [dB(µV)]	Reading AV [dB(µV)]	c.f [dB]	Result QP [dB(µV)]	Result AV [dB(µV)]	Limit QP [dB(µV)]	Limit AV [dB(µV)]	Margin QP [dB]	Margin AV [dB]
1	0.17633	40.0	13.7	10.2	50.2	23.9	64.7	54.7	14.5	30.8
2	2.82038	33.7	25.8	10.4	44.1	36.2	56.0	46.0	11.9	9.8

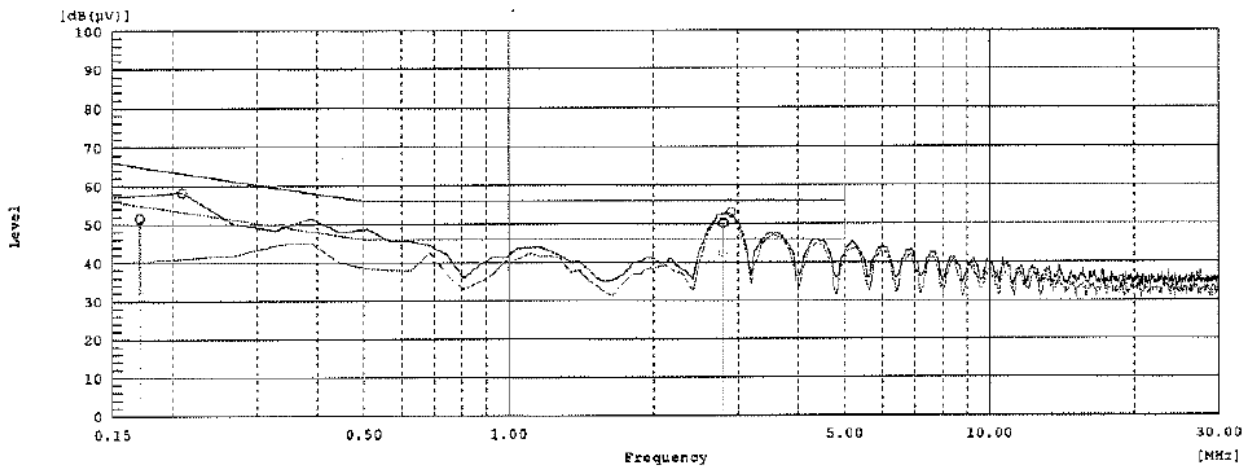

Final Result

--- N Phase ---

No.	Frequency [MHz]	Reading QP [dB(µV)]	Reading AV [dB(µV)]	c.f [dB]	Result QP [dB(µV)]	Result AV [dB(µV)]	Limit QP [dB(µV)]	Limit AV [dB(µV)]	Margin QP [dB]	Margin AV [dB]
1	0.1709	41.4	21.5	10.2	51.6	31.7	64.9	54.9	13.3	23.2
2	2.79889	39.7	31.9	10.4	50.1	42.3	56.0	46.0	5.9	3.7

Sample 3:

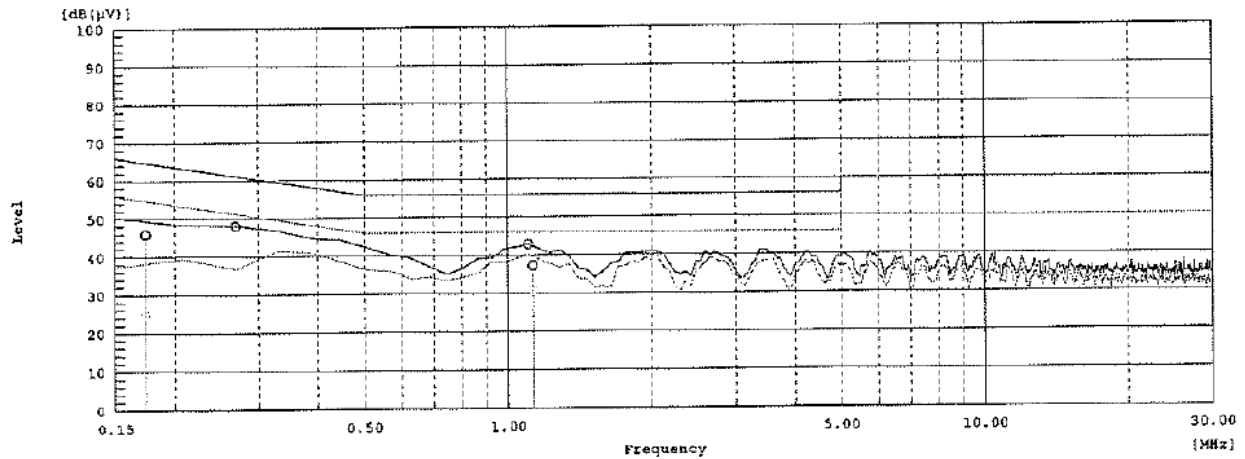

Final Result

--- L1 Phase ---

No.	Frequency [MHz]	Reading QP [dB(µV)]	Reading AV [dB(µV)]	c.f [dB]	Result QP [dB(µV)]	Result AV [dB(µV)]	Limit QP [dB(µV)]	Limit AV [dB(µV)]	Margin QP [dB]	Margin AV [dB]
1	0.17418	35.7	14.9	10.2	45.9	25.1	64.8	54.8	18.9	29.7
2	1.12968	26.9	20.5	10.3	37.2	30.8	56.0	46.0	18.8	15.2

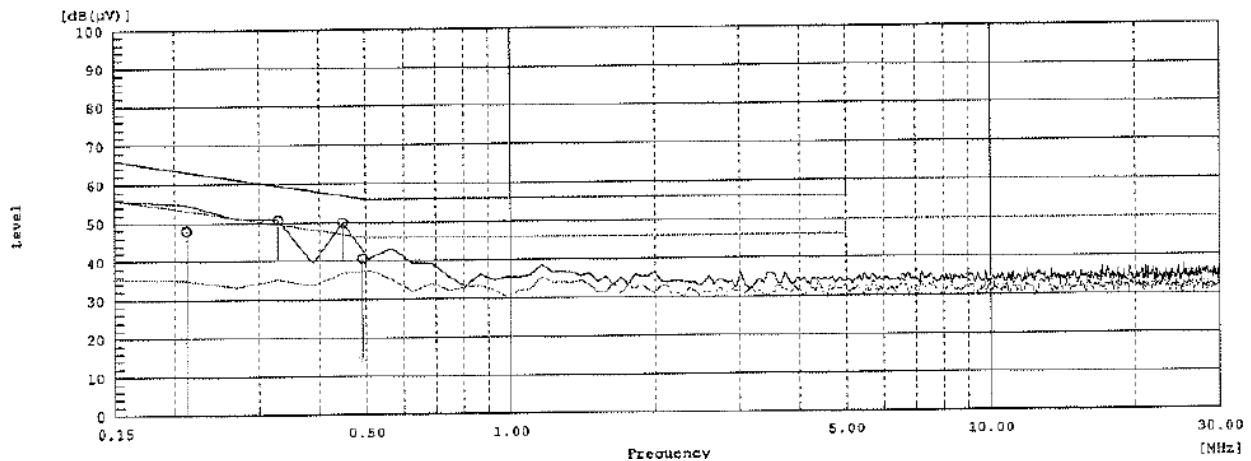

Final Result

--- L2 Phase ---

No.	Frequency [MHz]	Reading QP [dB(µV)]	Reading AV [dB(µV)]	c.f [dB]	Result QP [dB(µV)]	Result AV [dB(µV)]	Limit QP [dB(µV)]	Limit AV [dB(µV)]	Margin QP [dB]	Margin AV [dB]
1	0.21209	37.6	9.8	10.3	47.9	20.1	63.1	53.1	15.2	33.0
2	0.49268	30.1	4.6	10.4	40.5	15.0	56.1	46.1	15.6	31.1

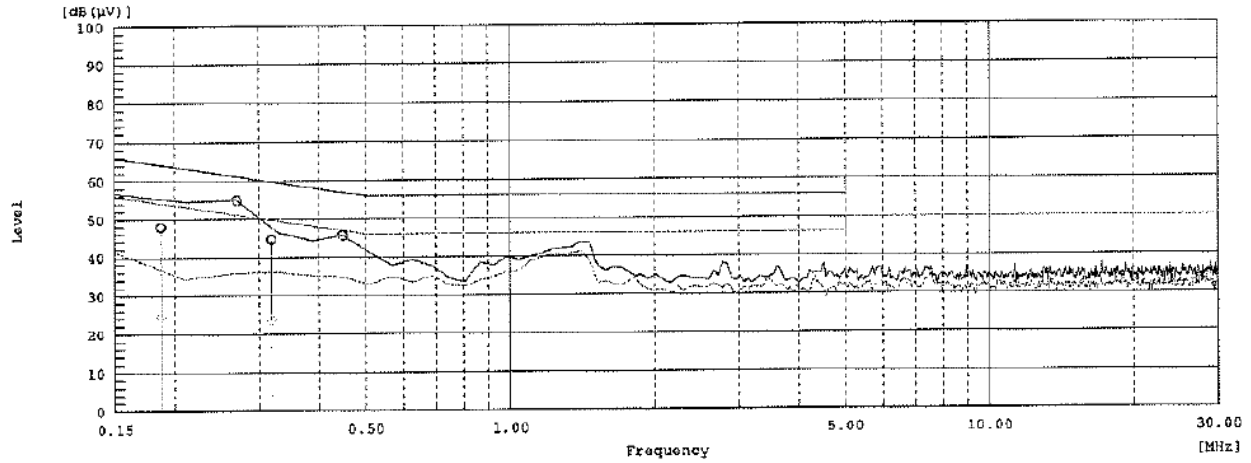

Final Result

--- L3 Phase ---

No.	Frequency [MHz]	Reading	Reading	c.f [dB]	Result	Result	Limit	Limit	Margin	Margin
		QP [dB(µV)]	AV [dB(µV)]		QP [dB(µV)]	AV [dB(µV)]	QP [dB(µV)]	AV [dB(µV)]	QP [dB]	AV [dB]
1	0.18707	37.9	14.4	10.2	48.1	24.6	64.2	54.2	16.1	29.6
2	0.31835	34.3	13.4	10.3	44.6	23.7	59.7	49.7	15.1	26.0

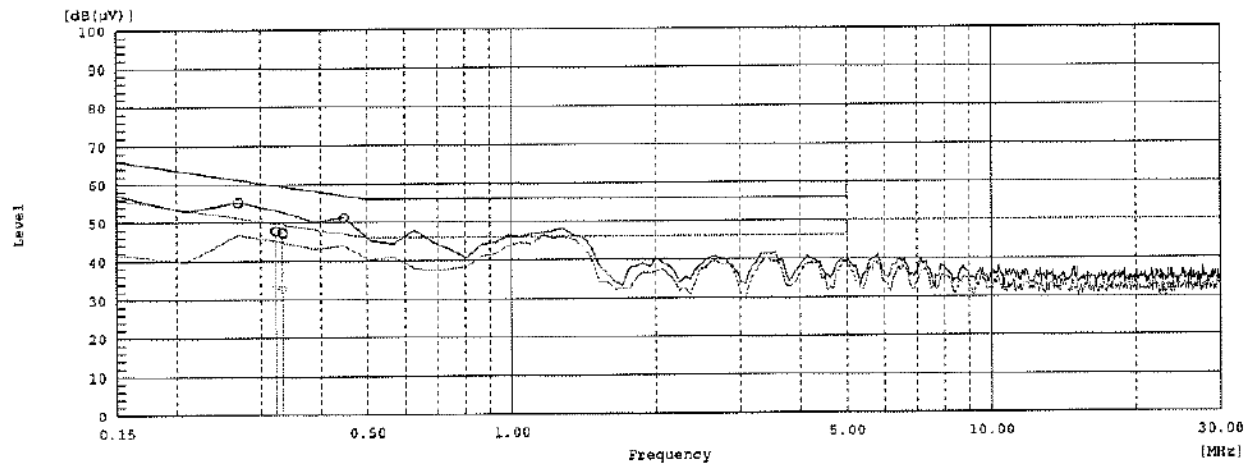

Final Result

--- N Phase ---

No.	Frequency [MHz]	Reading	Reading	c.f [dB]	Result	Result	Limit	Limit	Margin	Margin
		QP [dB(µV)]	AV [dB(µV)]		QP [dB(µV)]	AV [dB(µV)]	QP [dB(µV)]	AV [dB(µV)]	QP [dB]	AV [dB]
1	0.32301	37.6	22.7	10.2	47.8	32.9	59.6	49.6	11.8	16.7
2	0.33328	37.1	22.5	10.2	47.3	32.7	59.4	49.4	12.1	16.7

For load/control terminal: NA

Frequency (MHz)	Quasi-peak			Average		
	Corrected Reading (dBuV)	Limit (dBuV)	Margin (dB)	Corrected Reading (dBuV)	Limit (dBuV)	Margin (dB)
Note: * means the emission level 20dB below the relevant limit.						

- Remark:
1. Correct Factor = LISN Factor + Cable Loss, the value was added to Original Receiver Reading by the software automatically.
 2. Corrected Reading = Original Receiver Reading + Correct Factor
 3. Margin = Limit - Corrected Reading
 4. If the PK Corrected Reading is lower than AV limit, the AV test can be elided.

Example: Assuming LISN Factor = 10.00dB, Cable Loss = 2.00dB,
 Original Receiver Reading = 10.00dBuV, Limit = 66.00dBuV.
 Then Correct Factor = 10.00 + 2.00 = 12.00dB;
 Corrected Reading = 10dBuV + 12.00dB = 22.00dBuV;
 Margin = 66.00dBuV – 22.00dBuV = 44.00dB.

4 Mains Terminal Discontinuous Disturbance Voltage

Test result: NA

4.1 Block Diagram of Test Setup

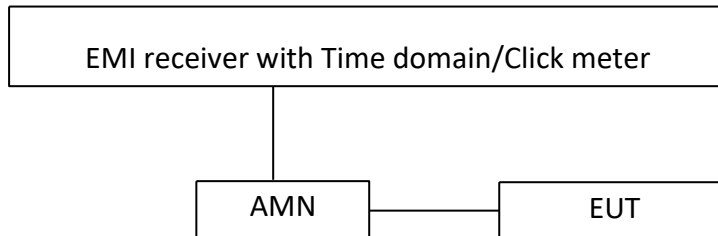

4.2 Test Setup and Test Procedure

Measurement was performed in shielded room.

EMI receiver compliance to CISPR 16-1-1 with time domain function used during measurement.

EUT arrangement was follow EN 55014-1 clause 5.2.

Operation conditions were follow EN 55014-1 clause 7.

0.15MHz, 0.5MHz, 1.4MHz and 30MHz were spot checked, and upper quartile methods used during measurement.

The final judgment of test result was according to figure 9 of EN 55014-1.

4.3 Test Protocol

Frequency (MHz)	0.15	0.5	1.4	30.0
Permitted limit for continuous interference (dB μ V)	66.0	56.0	56.0	60.0
Counted click/switch operation number				
Observed time (min)				
Click duration (ms)				
Click rate N				
Factor				
Permitted limits for clicks (dB μ v)				
Counted clicks exceeding the limits				
Test result				
Any other descriptions:				

5 Continuous Disturbance Power

Test result: NA

5.1 Limit

5.1.1 Limits for household and similar appliances

Frequency (MHz)	Permitted limit in dB μ V/m (Quasi-peak) of Measurement Distance 3m	Permitted limit in dB μ V/m (Quasi-peak) of Measurement Distance 10m
30 to 300	45 to 55*	35 to 45*

Note: 1. * means the limit increasing linearly with the frequency.
2. If the limit for the measurement with the average detector is met when using a receiver with a quasi-peak detector, the equipment under test shall be deemed to meet both limits and the measurement with the receiver with average detector need not be carried out.

5.1.2 Limits for electric tools

Frequency (MHz)	Rated motor power not exceeding 700W		Rated motor power above 700W and not exceeding 1000W		Rated motor power above 1000W	
	dB(pW) Quasi-peak	Average	dB(pW) Quasi-peak	Average	dB(pW) Quasi-peak	Average
30-300	45-55*	35-45*	49-59*	39-49*	55-65*	45-55*

Notes: 1. * means the limit increasing linearly with the frequency.
2. If the limit for the measurement with the average detector is met when using a receiver with a quasi-peak detector, the equipment under test shall be deemed to meet both limits and the measurement with the receiver with average detector need not be carried out.

5.2 Block Diagram and Test Setup

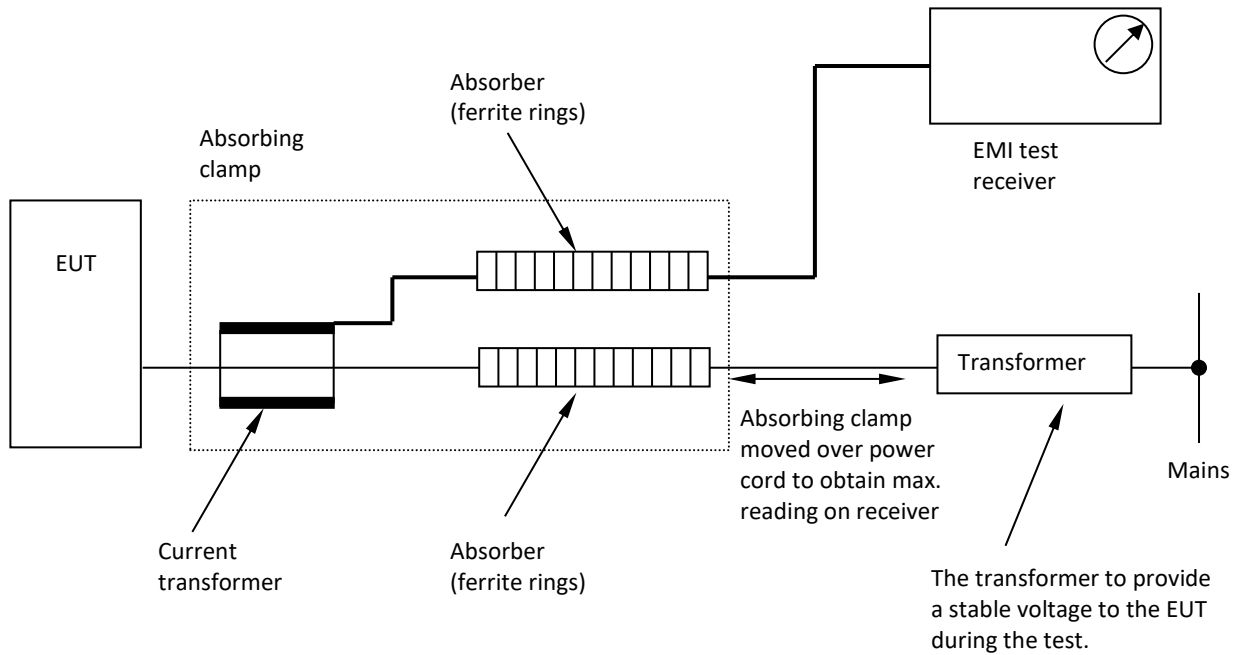

5.3 Test Setup and Test Procedure

Measurement was performed in shielded room.
 Instruments used were follow EN 55014-1 clause 6.1.
 Detailed test procedure and arrangement was follow EN 55014-1 clause 6.2 and 6.3.
 Operation conditions of EUT was according to EN 55014-1 clause 7.
 Frequency range 30MHz – 300MHz was checked and EMI receiver measurement bandwidth was set to 120kHz.

5.4 Test Protocol

Polarization	Frequency (MHz)	Corrected Reading (dBuV/m)	Corrected Factor (dB/m)	Limits (dBuV/m)	Margin (dBuV/m)
Horizontal					
Vertical					

- Remark: 1. Correct Factor = Antenna Factor + Cable Loss (+ Amplifier, for higher than 1GHz), the value was added to Original Receiver Reading by the software automatically.
 2. Corrected Reading = Original Receiver Reading + Correct Factor
 3. Margin = Limit - Corrected Reading
 4. If the PK Corrected Reading is lower than AV limit, the AV test can be elided.

Example: Assuming Antenna Factor = 30.20dB/m, Cable Loss = 2.00dB, Gain of Preamplifier = 32.00dB, Original Receiver Reading = 10.00dBuV, Limit = 40.00dBuV/m.
 Then Correct Factor = 30.20 + 2.00 – 32.00 = 0.20dB/m;
 Corrected Reading = 10dBuV + 0.20dB/m = 10.20dBuV/m;
 Margin = 40.00dBuV/m - 10.20dBuV/m = 29.80dB.

6 Radiated Emission

Test result: Pass

6.1 Limit

As for in the disturbance power test all emission readings from the EUT are lower than the applicable limits (Table 2a) reduced by the margin (Table 2b) and the maximum clock frequency is less than 30MHz, the EUT is deemed to comply with the Radiated Emission requirement without test.

Radiated emission limit from frequency range 30MHz – 1000MHz

Frequency (MHz)	Permitted limit in dB μ V/m (Quasi-peak) of Measurement Distance 3m	Permitted limit in dB μ V/m (Quasi-peak) of Measurement Distance 10m
30-230	40	30
230-1000	47	37

Note: 1. For the measurement distance other than 3m and 10m, the limit is varied according to 20dB/10 decades.
2. The gray rows are selected items.

6.2 Block Diagram and Test Setup

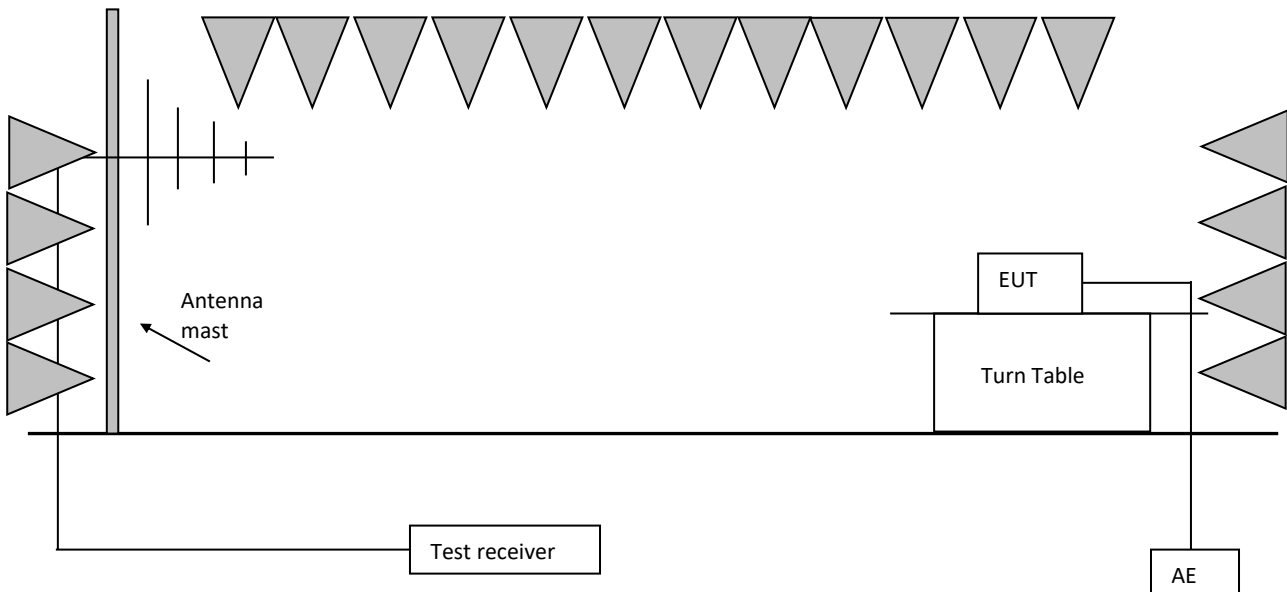

The measurement was applied in a semi-anechoic chamber.
Operation conditions of EUT was according to clause 6 of EN 55014-1.
Measurement was performed according to clause 10 of CISPR 32.
Setting of EUT is according to clause 5.3.4.3 of EN 55014-1.
The bandwidth setting on test receiver was 120kHz.
The frequency range from 30MHz to 1000MHz was checked.

6.3 Test Protocol

Sample 1:

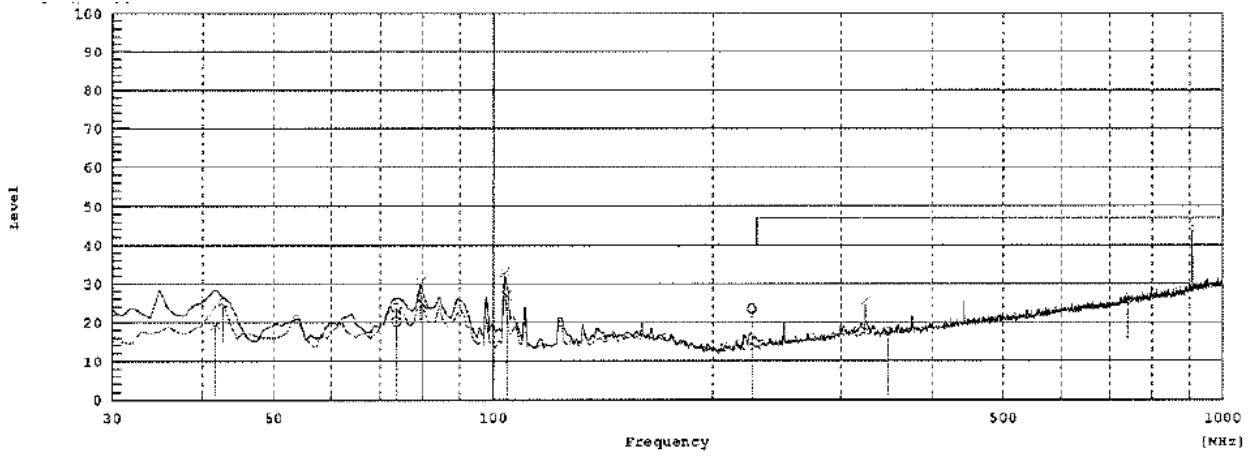

Final Result

No.	Frequency [MHz]	(P)	Reading QP [dB(µV)]	c.f [dB(1/m)]	Result QP [dB(µV/m)]	Limit QP [dB(µV/m)]	Margin QP [dB]	Height [cm]	Angle [°]
1	41.601	V	38.0	-18.7	19.3	40.0	20.7	200.0	130.9
2	73.669	H	41.3	-21.1	20.2	40.0	19.8	225.0	173.6
3	80.013	V	47.0	-22.2	24.8	40.0	15.2	101.0	52.6
4	104.341	V	47.2	-20.2	27.0	40.0	13.0	104.0	6.3
5	226.083	H	42.5	-19.0	23.5	40.0	16.5	101.0	277.3
6	347.532	H	33.0	-15.3	17.7	47.0	29.3	101.0	114.4

Sample 2:

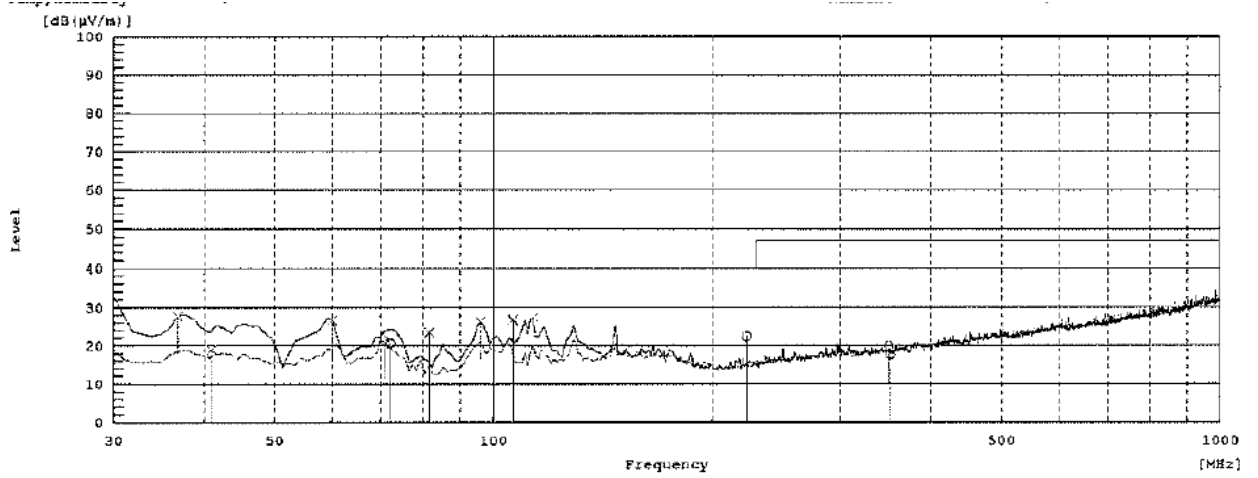

Final Result

No.	Frequency [MHz]	(P)	Reading QP [dB (µV)]	c.f [dB(1/m)]	Result QP [dB (µV/m)]	Limit QP [dB (µV/m)]	Margin QP [dB]	Height [cm]	Angle [°]
1	40.876	V	35.8	-16.9	18.9	40.0	21.1	103.0	103.1
2	72.197	H	39.4	-18.8	20.6	40.0	19.4	100.0	3.0
3	81.642	V	44.0	-20.5	23.5	40.0	16.5	106.0	250.2
4	106.385	V	45.0	-18.2	26.8	40.0	13.2	152.0	172.1
5	223.090	H	39.8	-17.4	22.4	40.0	17.6	100.0	249.0
6	351.628	H	31.0	-13.4	17.6	47.0	29.4	145.0	316.8

Sample 3:

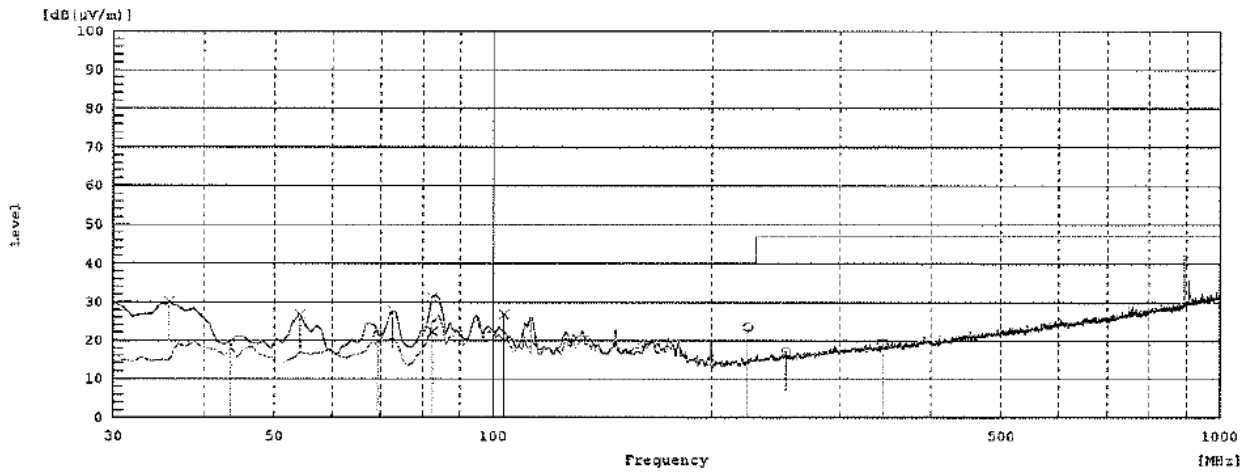

Final Result

No.	Frequency [MHz]	(P)	Reading QP [dB(µV)]	c.f [dB(1/m)]	Result QP [dB(µV/m)]	Limit QP [dB(µV/m)]	Margin QP [dB]	Height [cm]	Angle [°]
1	43.592	V	36.8	-17.9	18.9	40.0	21.1	104.0	243.5
2	69.453	H	40.3	-19.1	21.2	40.0	18.8	104.0	204.1
3	82.617	V	43.8	-21.4	22.4	40.0	17.6	101.0	5.0
4	103.426	V	46.3	-19.5	26.8	40.0	13.2	104.0	3.5
5	224.195	H	41.8	-18.3	23.5	40.0	16.5	142.0	25.9
6	343.530	H	33.9	-14.6	19.3	47.0	27.7	261.0	5.1

Immunity Test

Performance criteria

For safety reasons, some tests levels and test specifications have been chosen at levels higher than those required by the generic standard. The performance criteria A, B and C listed below apply.

Criterion A: During the test referring to this performance criterion, the RCD shall remain closed at continuously applied residual current of $0,3 I_{\Delta n}$ and shall trip at $1,25 I_{\Delta n}$.

Criterion B: During the tests referring to this performance criterion, the RCD shall not trip. After the test, verification of correct operation in case of sudden appearance of sinusoidal AC residual current at $I_{\Delta n}$ only shall be checked, in order to verify that the device operates as intended.

Criterion C: During the test referring to this performance criterion, the RCD may trip. After the test, with the sample in closed position, verification of correct operation in case of sudden appearance of sinusoidal AC residual current at $I_{\Delta n}$ only shall be checked.

Basic EMC standard for immunity test

IEC 61000-4-2: Electromagnetic Compatibility (EMC) – Part 4-2: testing and measurement techniques – electrostatic discharge immunity test

IEC 61000-4-3: Electromagnetic Compatibility (EMC) – Part 4-3: testing and measurement techniques – radiated, radio frequency, electromagnetic field immunity test

IEC 61000-4-4: Electromagnetic Compatibility (EMC) – Part 4-4: testing and measurement techniques – electric fast transient/burst immunity test

IEC 61000-4-5:2014: Electromagnetic Compatibility (EMC) – Part 4-5: Testing and measurement techniques – Surge immunity test
IEC 61000-4-5:2014/AMD1:2017

IEC 61000-4-6: Electromagnetic Compatibility (EMC) – Part 4-6: testing and measurement techniques – immunity to conducted disturbance, induced by radio frequency field

IEC 61000-4-11, Electromagnetic compatibility (EMC) – Part 4-11: Testing and measurement techniques – Voltage dips, short interruptions and voltage variations immunity tests for equipment with input current up to 16 A per phase

IEC 61000-4-16:2015, Electromagnetic compatibility (EMC) – Part 4-16: Testing and measurement techniques – Test for immunity to conducted, common mode disturbances in the frequency range 0 Hz to 150 kHz

7 Surge Immunity Test

Test result: PASS

7.1 Severity Level and Performance Criterion

7.1.1 Test Level

Level	Open-circuit test voltage $\pm 10\%$ kV
1	0.5
2	1.0
3	2.0
4	4.0
X*	5.0

Notes: 1. "X" is an open class. This level can be specified in the product specification.
 2. The gray rows are the selected level.
 3. For SRCs and PRCDs: Level 3 and Level 4 applied.

7.1.2 Performance Criterion

Performance criterion: B/C*

*: Test T 5a: Performance criterion C.

Test T 5b: Performance criterion B for RCCBs and RCBOs,
 Performance criterion C for SRCs and PRCDs.

7.2 Block Diagram of Test Setup

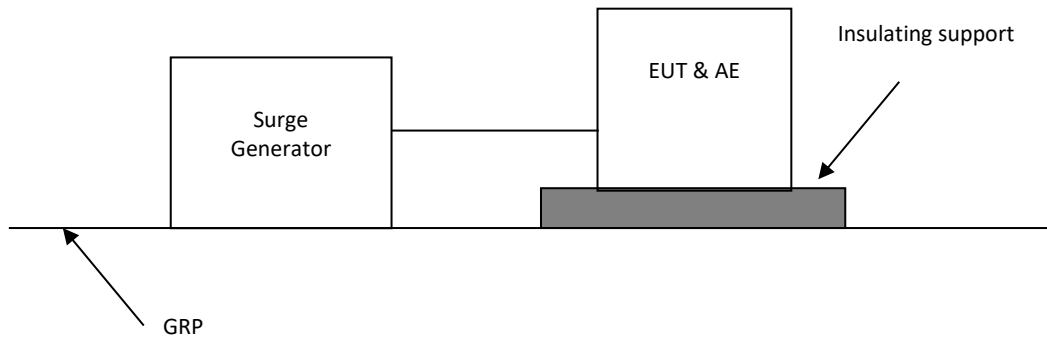

7.3 Test Setup and Test Procedure

Measurement was performed in shielded room.

Measurement and setting of EUT was applied according to IEC61000-4-5 clause 7.

The test method and equipment were specified by IEC61000-4-5 with modifications by EN 61543, Table 1.

7.4 Test Protocol

Test No.	Level [kV]	Polarity +/-	Angle	Line for test	Pass/Fail/NA
1	4	+/-	0°	a.c. Mains (line to line)	Pass
2	4	+/-	90°	a.c. Mains (line to line)	Pass
3	5	+/-	0°	a.c. Mains (line to earth)	Pass
4	5	+/-	90°	a.c. Mains (line to earth)	Pass

Additional tests (applicable only while the RCD tripped)

Test No.	Level [kV]	Polarity (Angel) +/-	Line for test	Pass/Fail
1	2/1/0,5	+/- (0°, 90°)	a.c. Mains (line to line)	NA
2	4/2/1/0,5	+/- (0°, 90°)	a.c. Mains (line to earth)	NA

Notes: "NA" means not applicable.

Observation: During the test, no samples were tripped.

After the test, samples were tripped within 300ms when they were loaded with $I_{\Delta n}$.

Conclusion: The EUT met the requirements of Performance Criterion B.

8 Conducted Sine-wave Form Voltages or Currents

Test result: **PASS**

8.1 Severity Level and Performance Criterion

8.1.1 Test Level

Frequency range 150kHz – 80MHz		
Level	Voltage level (e.m.f.)	
	U_0 [dB(uV)]	U_0 (V)
1	120	1
2	130	3
3	140	10
X	Special	Special

Notes: 1. "X" is an open level.
2. The gray row is the selected test level. Level 2 for RCDs with $I_{\Delta n} < 30\text{mA}$ and PRCDs/SRCDs, Level 3 for RCDs with $I_{\Delta n} \geq 30\text{mA}$.

8.1.2 Performance Criterion

Performance criterion: A

8.2 Block Diagram of Test Setup

8.2.1 Block Diagram for a.c./d.c input power line

Block Diagram for a.c./d.c input power line

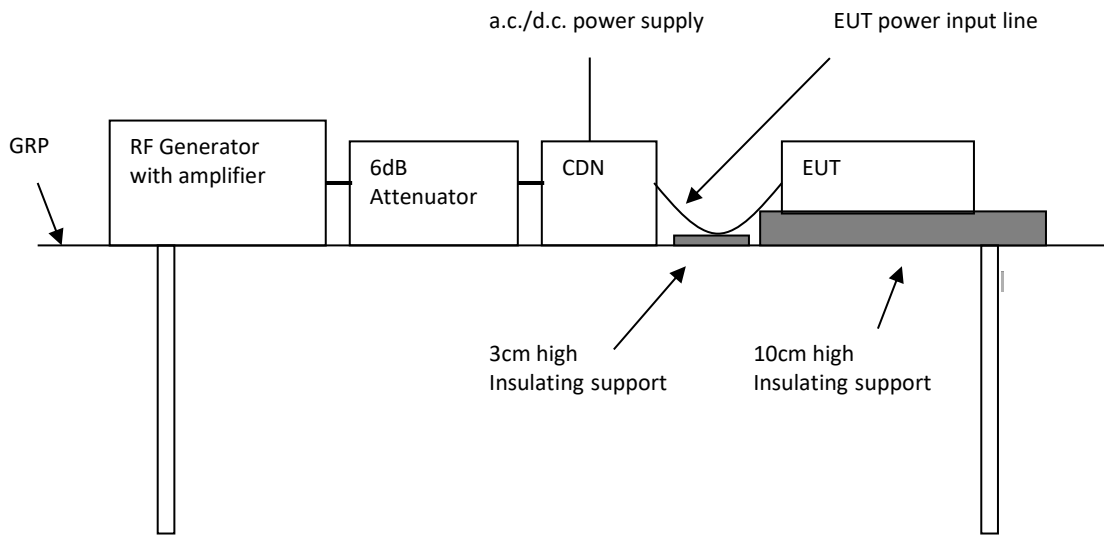

8.2.2 Block Diagram for output a.c./d.c. power line or signal/control lines

Unshielded line

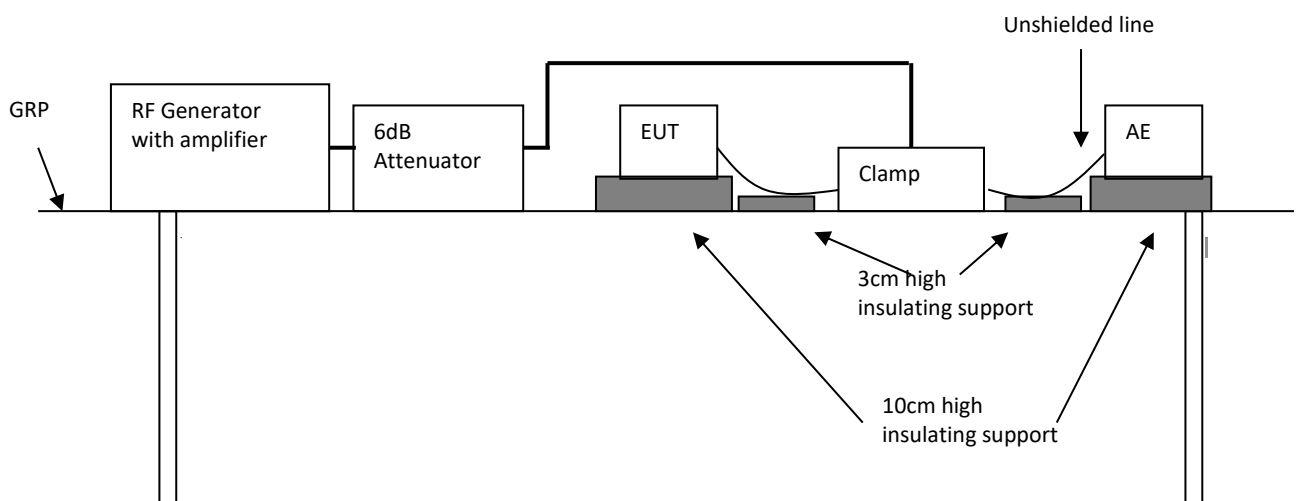

Shielded line

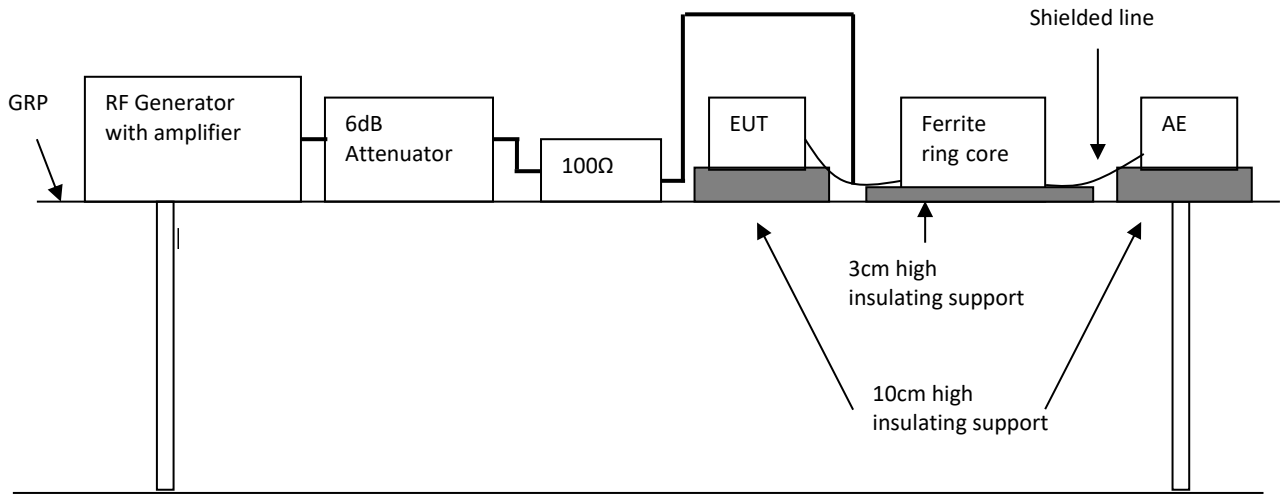

8.3 Test Setup and Test Procedure

Measurement and setting of EUT was applied according to IEC61000-4-6 clause 7. The test method and equipment was specified by IEC61000-4-6 with additions and modifications by EN 61543, Table 1.

8.4 Test Protocol

Test No.	Frequency (MHz)	Level V (r.m.s.)	Modulation	Injected point	Pass/Fail/NA
1	0.15~80	10	1kHz, 80%, SW, AM, 1% step size	a.c. Mains	Pass
2	0.15~80	3	1kHz, 80%, SW, AM, 1% step size	a.c. Mains	NA

Observation: When samples were loaded $0.3 I_{\Delta n}$ during the test, no sample were tripped.
 When samples were loaded $1.25 I_{\Delta n}$ during the test, the samples tripped.

Conclusion: The EUT met the requirements of Performance Criterion A.

9 Radiated Magnetic Field

Test result: **PASS**

9.1 Severity Level and Performance Criterion

9.1.1 Test Level

Level	Test field strength V/m
1	1
2	3
3	10
X	Special

Notes: 1. X is an open test level. This level may be given in the product specification.
 2. The gray row is the selected test level.
 3. For SRCDs and PRCDs: Level 2 applied.

9.1.2 Performance Criterion

Performance criterion: A

9.2 Block Diagram of Test Setup

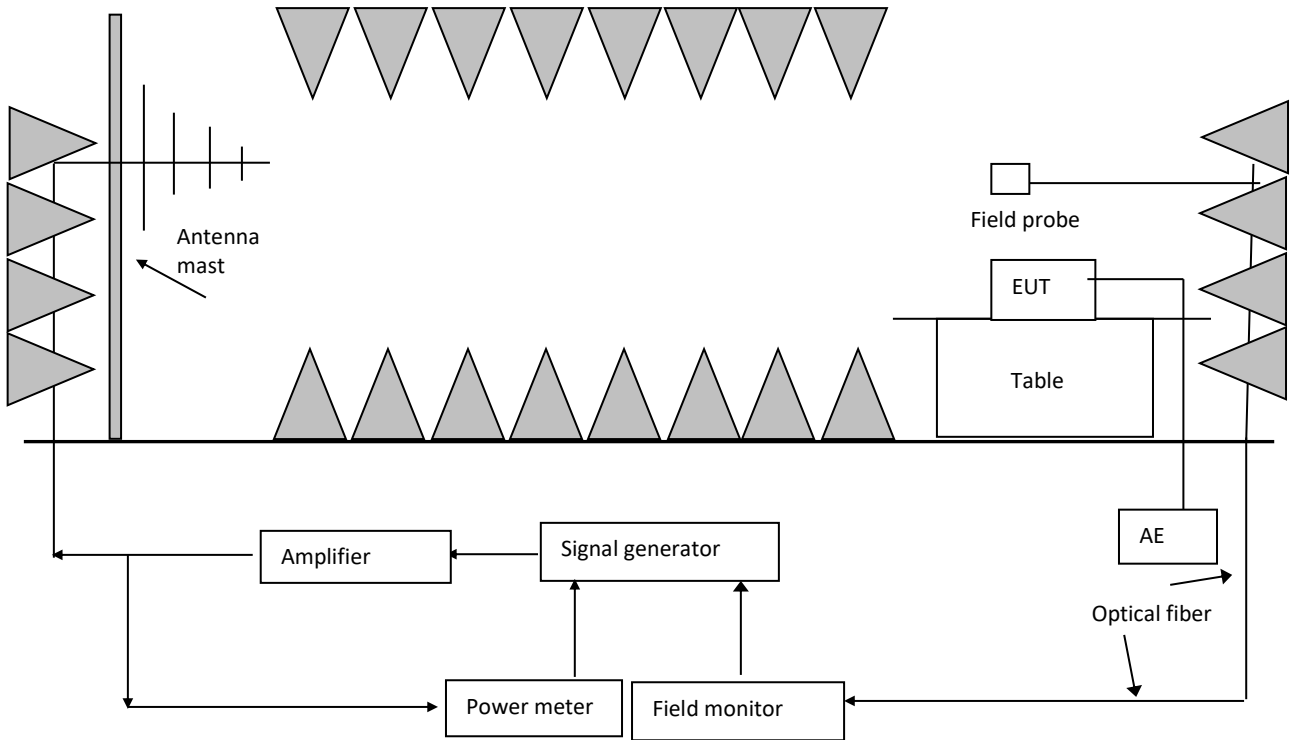

9.3 Test Setup and Test Procedure

Measurement was performed in full-anechoic chamber.
Measurement and setting of EUT was applied according to IEC61000-4-3 clause 7.
The test method and equipment were specified by IEC61000-4-3 with additions and modifications by EN 61543, Table 1.

9.4 Test Protocol

Test No.:	Frequency (MHz)	Polarization	Test level V/m	Modulation	Exposed location	Pass/Fail/NA	Comment
1	80-1000	H & V	10	1kHz, 80%, SW, AM, 1% step size	All sides	Pass	-
2	1400-6000	H & V	10	1kHz, 80%, SW, AM, 1% step size	All sides	Pass	-

Observation: When samples were loaded $0.3 I_{\Delta n}$ during the test, no samples were tripped.
 When samples were loaded $1.25 I_{\Delta n}$ during the test, the samples tripped.

Conclusion: The EUT met the requirements of Performance Criterion A.

10 Electric Fast Transient/Burst Immunity Test

Test result: **PASS**

10.1 Severity Level and Performance Criterion

10.1.1 Test Level

Open circuit output test voltage ($\pm 10\%$) and repetition rate of the impulses ($\pm 20\%$)				
Level	On power port, PE		On I/O (input & output) signal, data and control ports	
	Voltage peak kV	Repetition rate kHz	Voltage peak kV	Repetition rate kHz
1	0.5	5	0.25	5
2	1	5	0.5	5
3	2	5	1	5
4	4	5	2	5
X	Special	Special	Special	Special

Notes: 1. "X" is an open level. The level has to be specified in the dedicated equipment specification.
2. The gray rows were the selected test level.
3. For SRCs and PRCDs: Level 3 applied.

10.1.2 Performance Criterion

Performance criterion: B

10.2 Block Diagram of Test Setup

10.2.1 Block Diagram for input a.c./d.c. power line

For table-top equipment

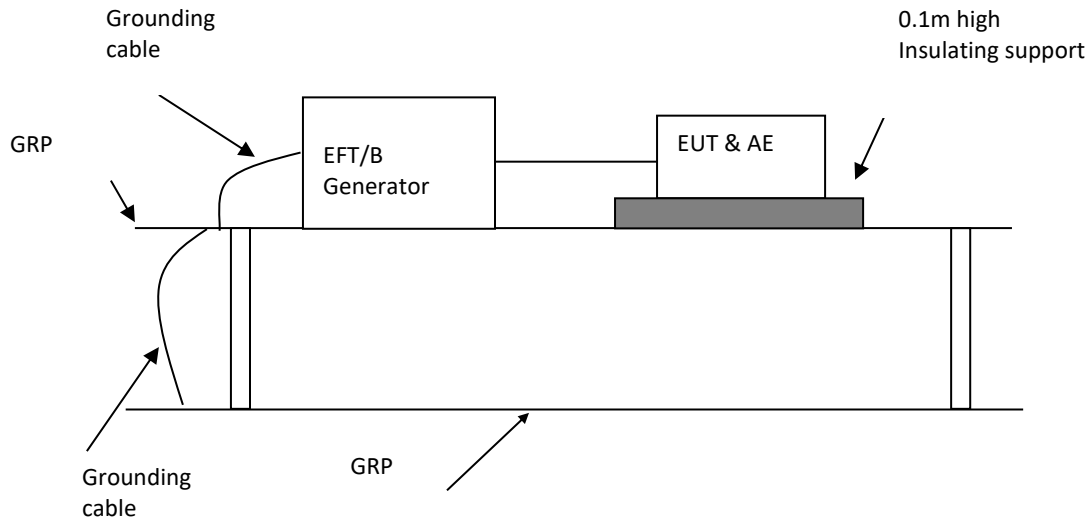

For floor standing equipment

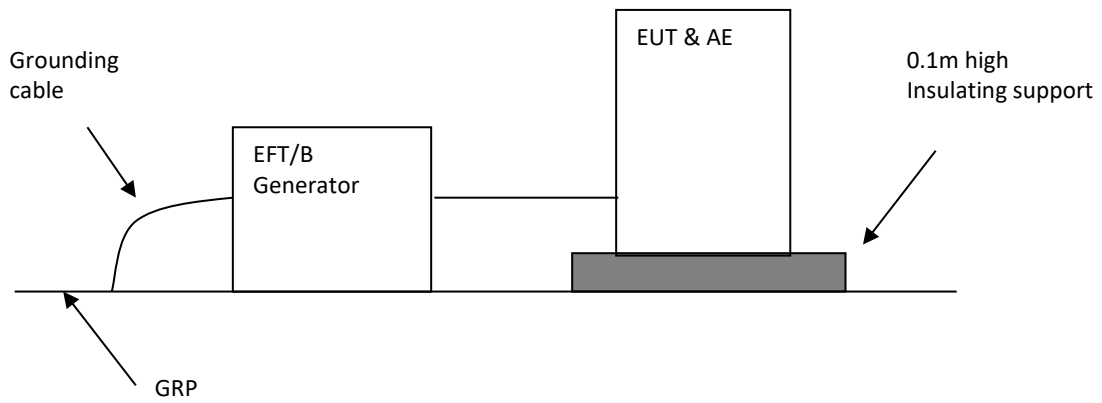

10.2.2 Block Diagram for output a.c./d.c. power line or signal/control lines

For table-top equipment

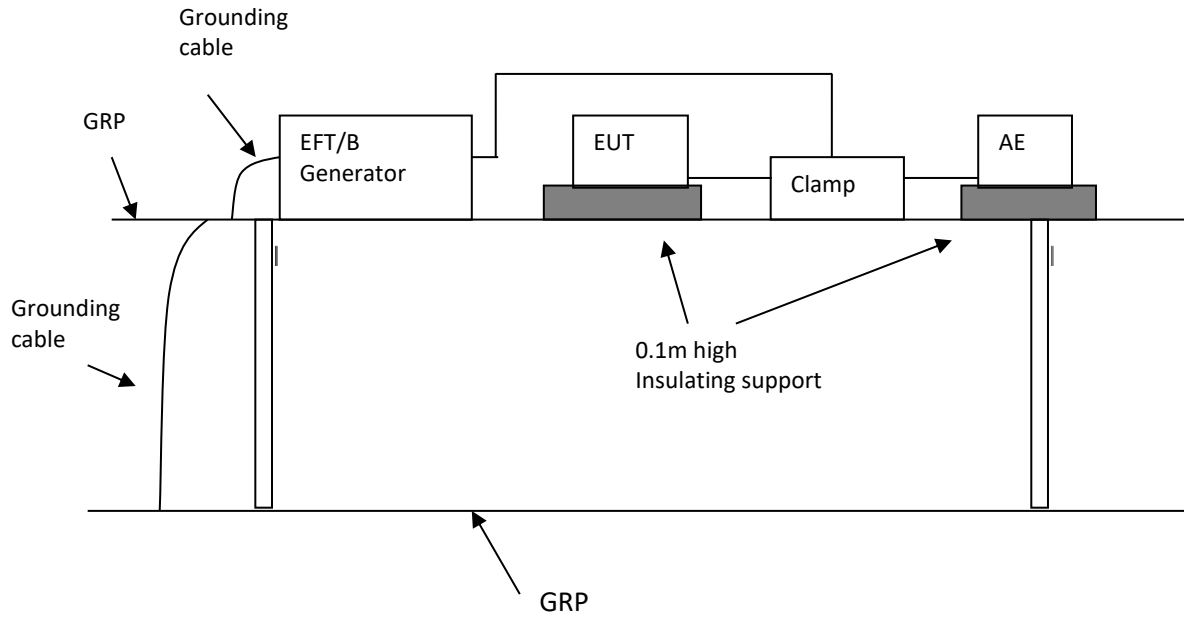

For floor standing equipment

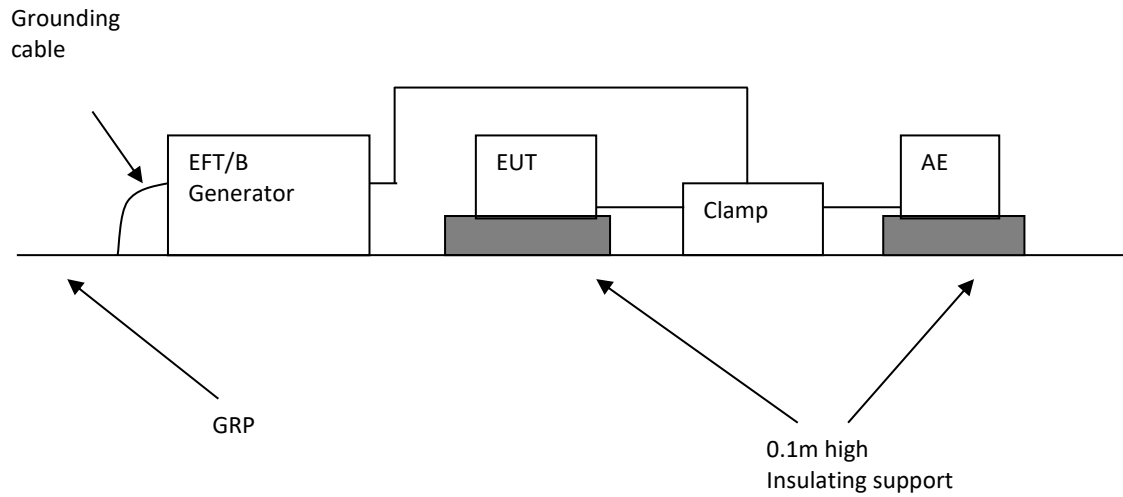

10.3 Test Setup and Test Procedure

Measurement was performed in shielded room.

Measurement and setting of EUT was applied according to IEC61000-4-4 clause 7.2.

The test method and equipment were specified by IEC61000-4-4 with additions and modifications by EN 61543, Table 1.

10.4 Test Protocol

Test No.	Level [kV]	Polarity +/-	Repetition rate kHz	Line for test	Pass/Fail/NA
1	4	+/-	5	a.c. power ports	Pass
2	2	+/-	5	a.c. power ports	NA

Observation: During the test, no samples were tripped.

After the test, samples were tripped within 300ms when they were loaded with $I_{\Delta n}$.

Conclusion: The EUT met the requirements of Performance Criterion B.

11 Conducted common mode disturbances in the frequency range lower than 150 kHz

Test result: **PASS**

11.1 Severity Level and Performance Criterion

11.1.1 Test Level

Frequency range	RMS current value for Level 2 $I_{\Delta n} < 30 \text{ mA}$	RMS current value for Level 3 $I_{\Delta n} \geq 30 \text{ mA}$
1 kHz to 1,5 kHz	2 mA	6,6 mA
1,5 kHz to 15 kHz	2 mA to 20 mA*	6,6 mA to 66 mA *
15 kHz to 150 kHz	20 mA	66 mA
Notes: 1. * means the current level increases from 1,5 kHz to 15 kHz at 20 dB/decade. 2. Current levels are taking into account a common mode impedance of 150 Ω .		

11.1.2 Performance Criterion

Performance criterion: A

11.2 Block Diagram of Test Setup

Block Diagram for a.c input power line

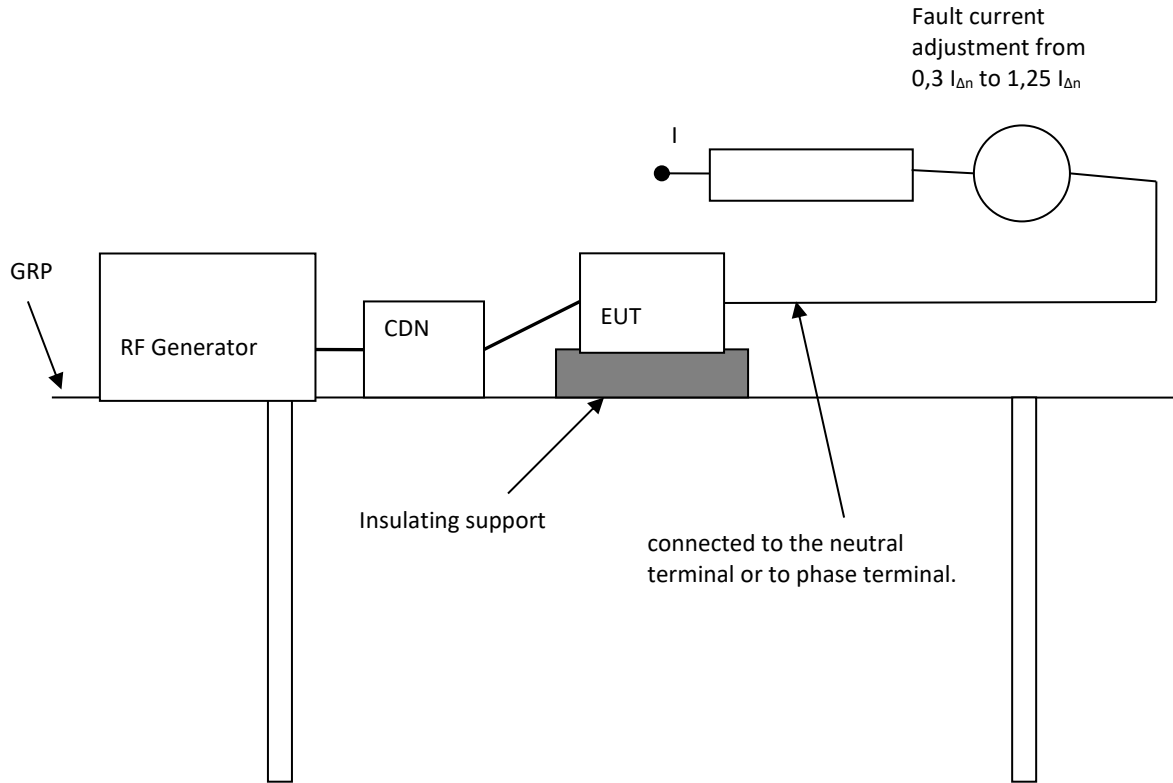

11.3 Test Setup and Test Procedure

Measurement and setting of EUT was applied according to IEC61000-4-16 clause 7 and clause 8 . The test method and equipment was specified by IEC61000-4-16 with additions and modifications by EN 61543, Table 1.

11.4 Test Protocol

Test No.	Frequency (kHz)	Test Level	Injected point	Result	Comment
1	1 ~ 150	Test Level 2	a.c. Mains	NA	
2	1 ~ 150	Test Level 3	a.c. Mains	Pass	

Observation: When samples were loaded $0.3 I_{\Delta n}$ during the test, no sample were tripped.
 When samples were loaded $1.25 I_{\Delta n}$ during the test, the samples tripped.

Conclusion: The EUT met the requirements of Performance Criterion A.

12 Electrostatic Discharge (ESD)

Test result: **PASS**

12.1 Severity Level and Performance Criterion

12.1.1 Test Level

1a – Contact discharge		1b – Air discharge	
Level	Test voltage kV	Level	Test voltage kV
1	2	1	2
2	4	2	4
3	6	3	8
4	8	4	15
X	Special	X	Special

Notes: 1. "X" is an open level. The level has to be specified in the dedicated equipment specification.
If higher voltages than those shown are specified, special test equipment may be needed.
2. The gray rows were the selected test level.

12.1.2 Performance Criterion

Performance criterion: B

12.2 Block Diagram of Test Setup

For table-top equipment

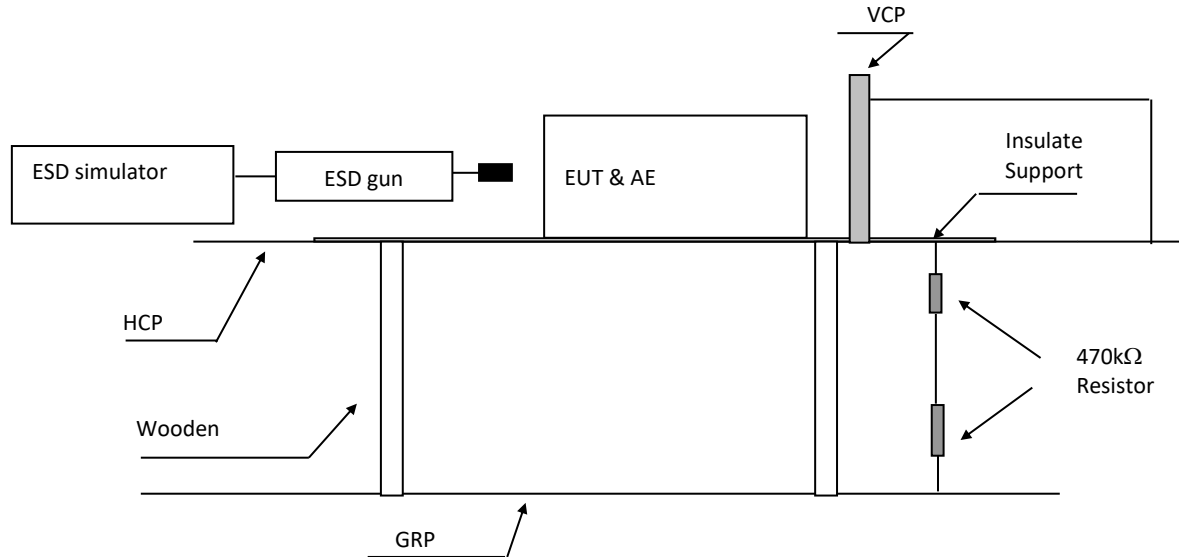

Note: HCP means Horizontal Coupling Plane
VCP means Vertical Coupling Plane
GRP means Ground Reference Plane
Wooden support is a 0.8m height table

For floor standing equipment

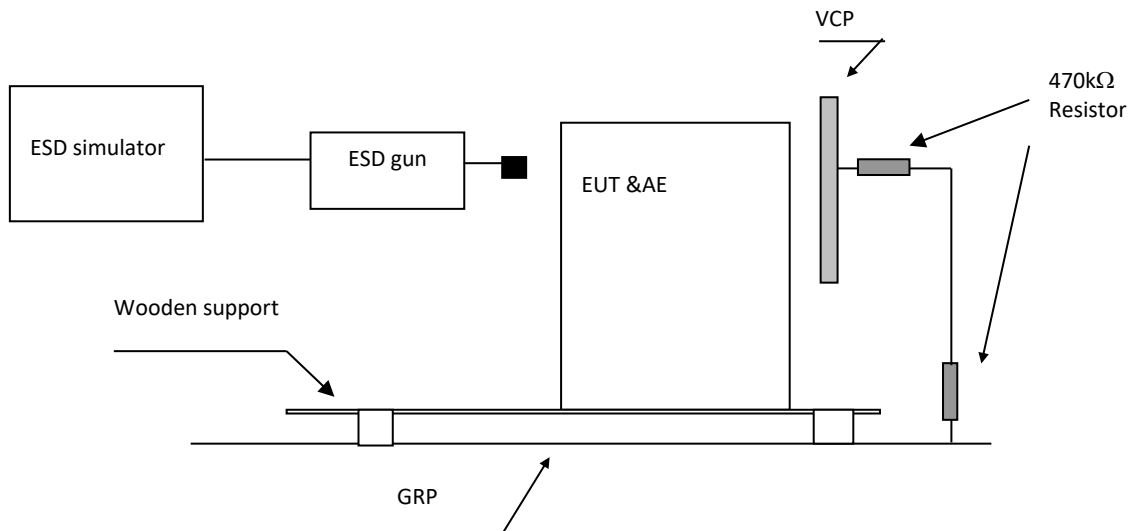

Note: VCP means Vertical Coupling Plane
GRP means Ground Reference Plane
Wooden support is a 0.1m height rack

12.3 Test Setup and Test Procedure

Measurement was performed in shielded room.

Measurement and setting of EUT was applied according to IEC61000-4-2 clause 7.1.

The test method and equipment was specified by IEC61000-4-2 with additions and modifications by EN61543, Table 1.

12.4 Test Protocol

Direct discharges were applied at the following selected points:

Test point #	Test level [kV]	Air/Contact	Polarity (+/-)	Pass/Fail/NA	Comment
A	6	Contact	+/-	Pass	All touchable screws of enclosure
B	6	Contact	+/-	Pass	Accessible metal parts of the EUT
C	8	Air	+/-	Pass	Air gap of the switch, button
D	8	Air	+/-	Pass	The air in-taking opening
E	8	Air	+/-	Pass	Slots around the EUT

Indirect contact discharges were applied to the VCP and the HCP at the following selected points:

For table top equipment

Point	Description	Point	Pass/Fail/NA
HCP f	0,1m from the front of the EUT	Edge of centre, corner on HCP	Pass
HCP b	0,1m from the back of the EUT	Edge of centre, corner on HCP	Pass
HCP r	0,1m from the right side of the EUT	Edge of centre, corner on HCP	Pass
HCP l	0,1m from the left side of the EUT	Edge of centre, corner on HCP	Pass
VCP f	0,1m from the front of the EUT	Edge of centre, corner on VCP	Pass
VCP b	0,1m from the back of the EUT	Edge of centre, corner on VCP	Pass
VCP r	0,1m from the right of the EUT	Edge of centre, corner on VCP	Pass
VCP l	0,1m from the left of the EUT	Edge of centre, corner on VCP	Pass

For floor standing equipment

Point	Description	Point	Pass/Fail/NA
VCP f	0,1m from the front of the EUT	Edge of centre, corner on VCP	-
VCP b	0,1m from the back of the EUT	Edge of centre, corner on VCP	-
VCP r	0,1m from the right of the EUT	Edge of centre, corner on VCP	-
VCP l	0,1m from the left of the EUT	Edge of centre, corner on VCP	-

Observation: During the test, no samples were tripped.

After the test, samples were tripped within 300ms when they were loaded with $I_{\Delta n}$.

Conclusion: The EUT met the requirements of Performance Criterion B.

13 Voltage dips and interruptions

Test result

Pass

13.1 Severity Level and Performance Criterion

13.1.1 Test level and performance criterion

Test level (% Ut)	Voltage dip and short interruptions (% Ut)	Duration (in period)	Performance criterion
0	100	1	B
0	100	250 for 50 Hz / 300 for 60 Hz	C
70	30	25 for 50 Hz / 30 for 60 Hz	B

Notes: The gray rows are selected test level.

13.2 Test Setup

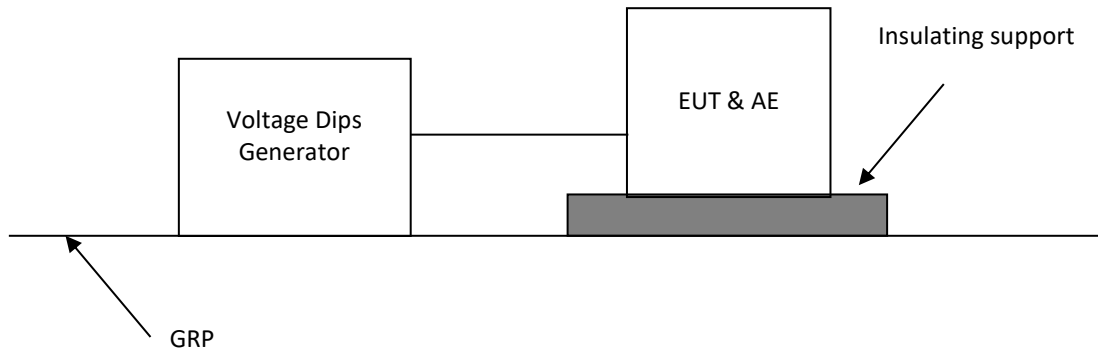

13.3 Test Procedure

Measurement was performed in shielded room.

Measurement procedure was applied according to EN 61000-4-11 clause 8.

The test method and equipment was specified by IEC61000-4-2 with additions and modifications by EN61543, Table 1.

13.4 Test Result

Test no.	Dips to (% Ut)	Voltage dip and short interruptions (% Ut)	Duration (in periods)	Pass/Fail/NA
1	70	30%	25	Pass
2	0	100%	1	Pass
3	0	100%	250	Pass

Observation: During the test, no samples were tripped.
 After the test, samples were tripped within 300ms when they were loaded with $I_{\Delta n}$.

Conclusion: The EUT met the requirements of Performance Criterion B and C.

Appendix I: Photograph of Equipment Under Test

Photos of sample: 1P+N

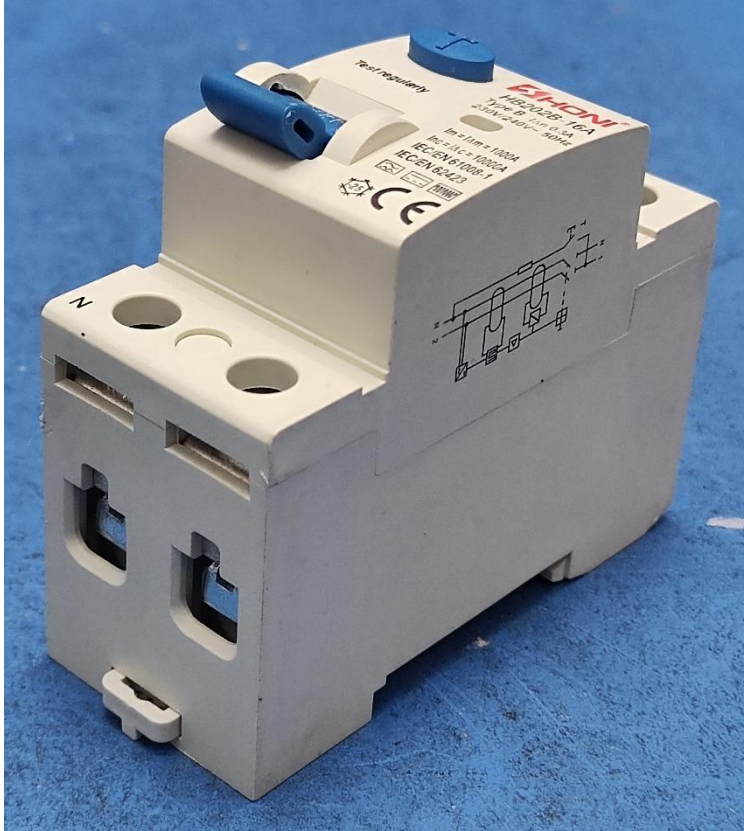

Photos of sample: 1P+N



Photos of sample: 1P+N

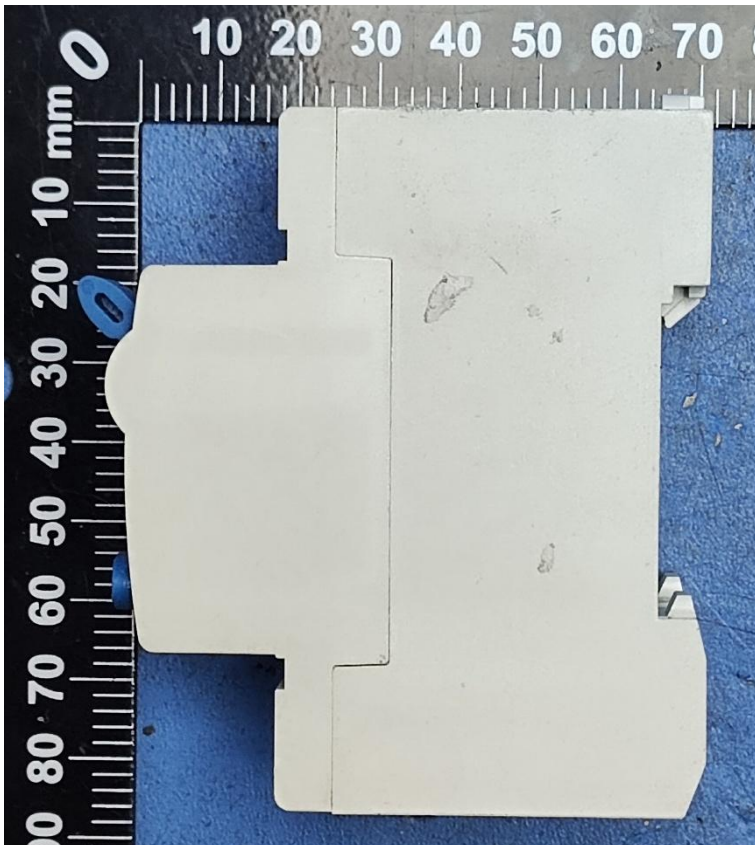
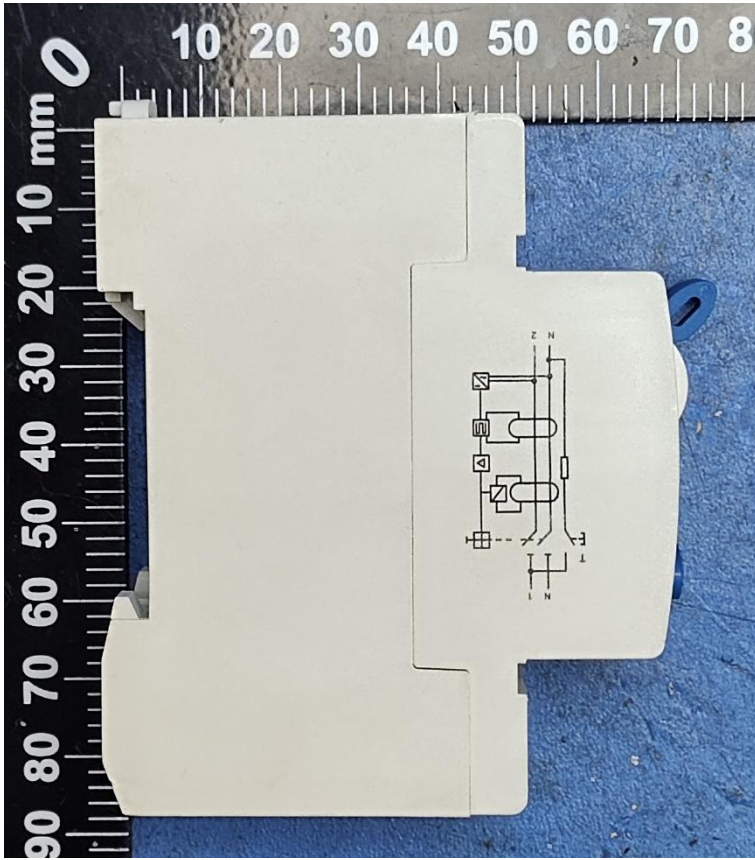

Photos of sample: 1P+N

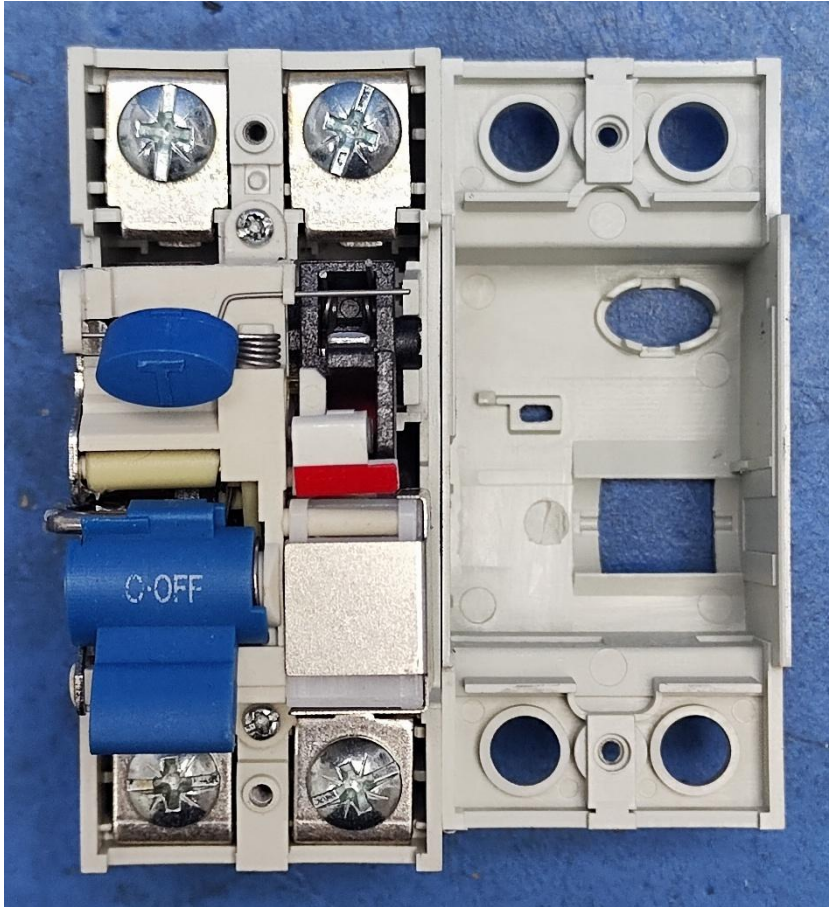

Photos of sample: 1P+N

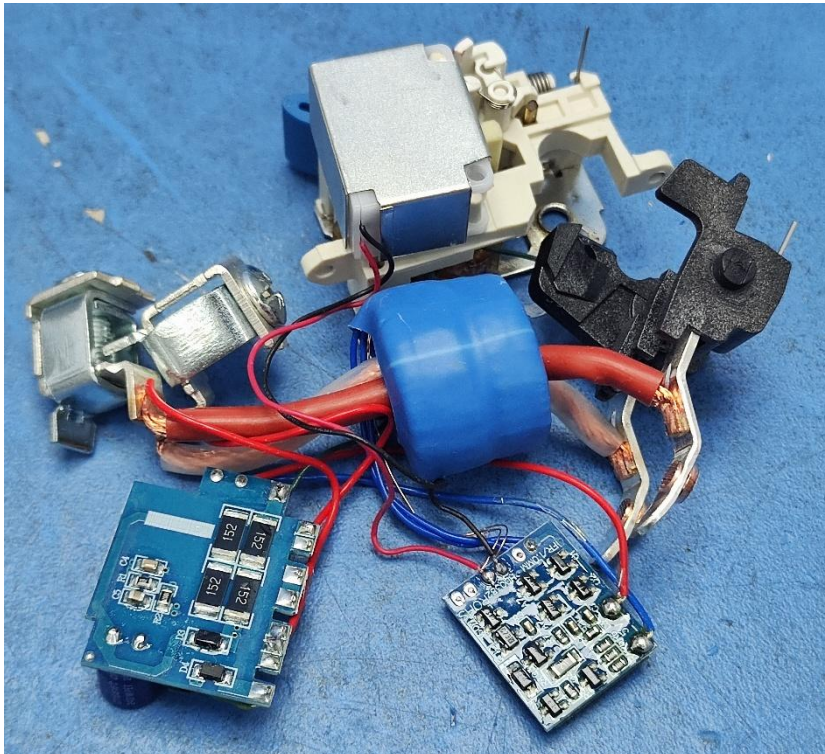
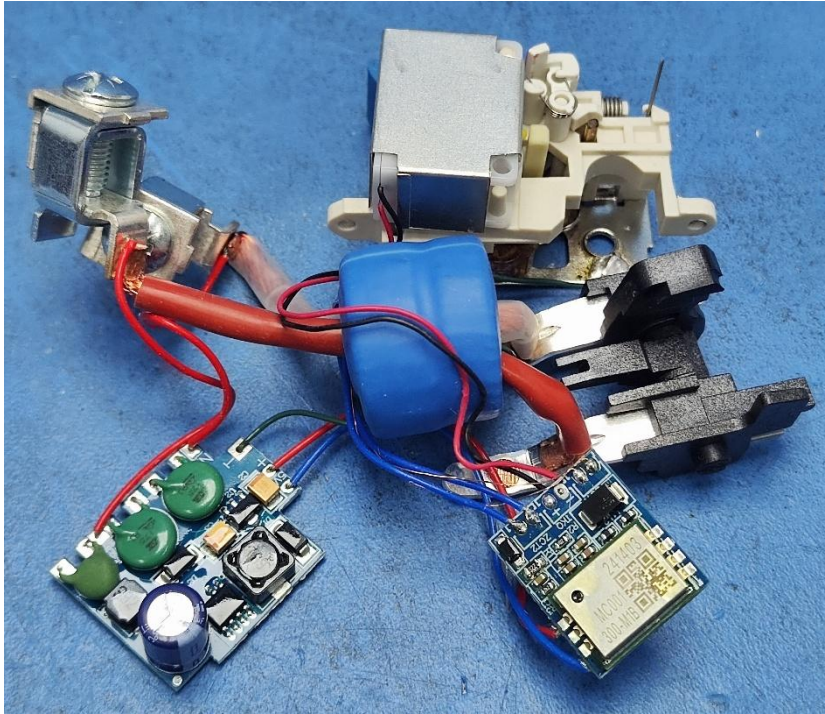

Photos of sample: 3P+N

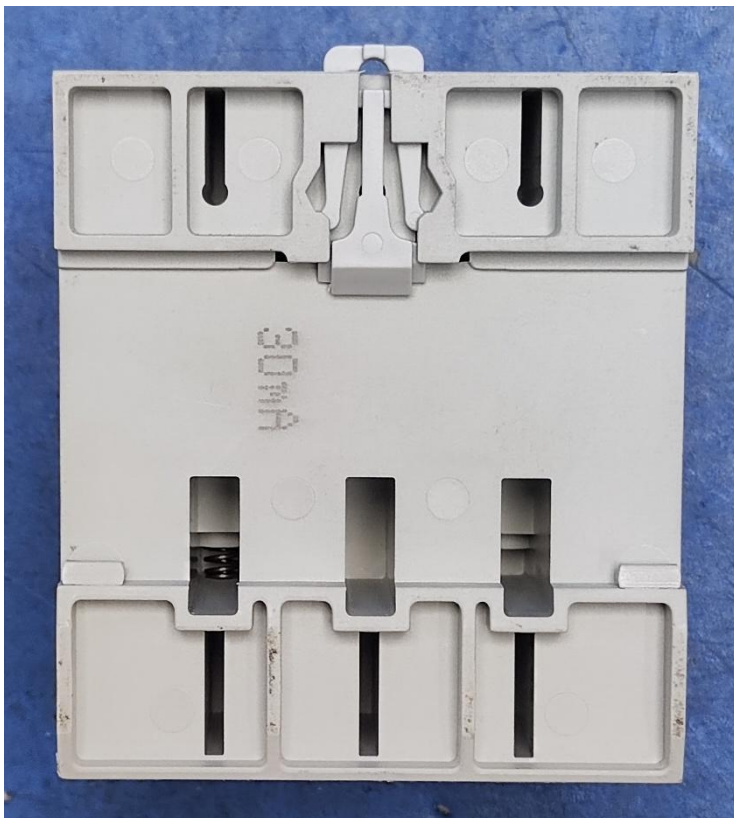
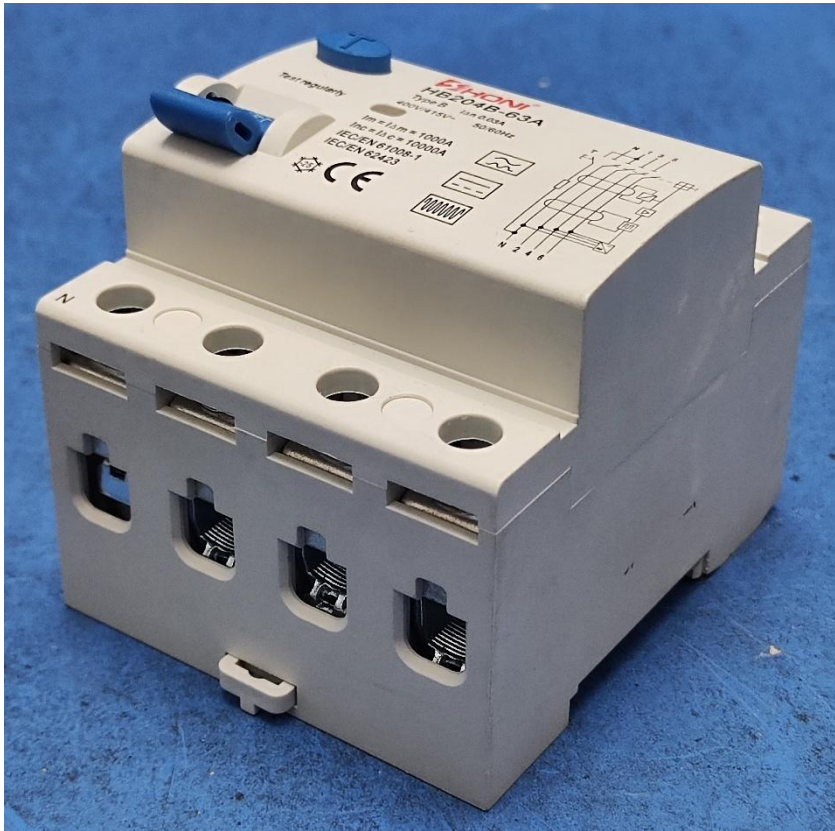

Photos of sample: 3P+N

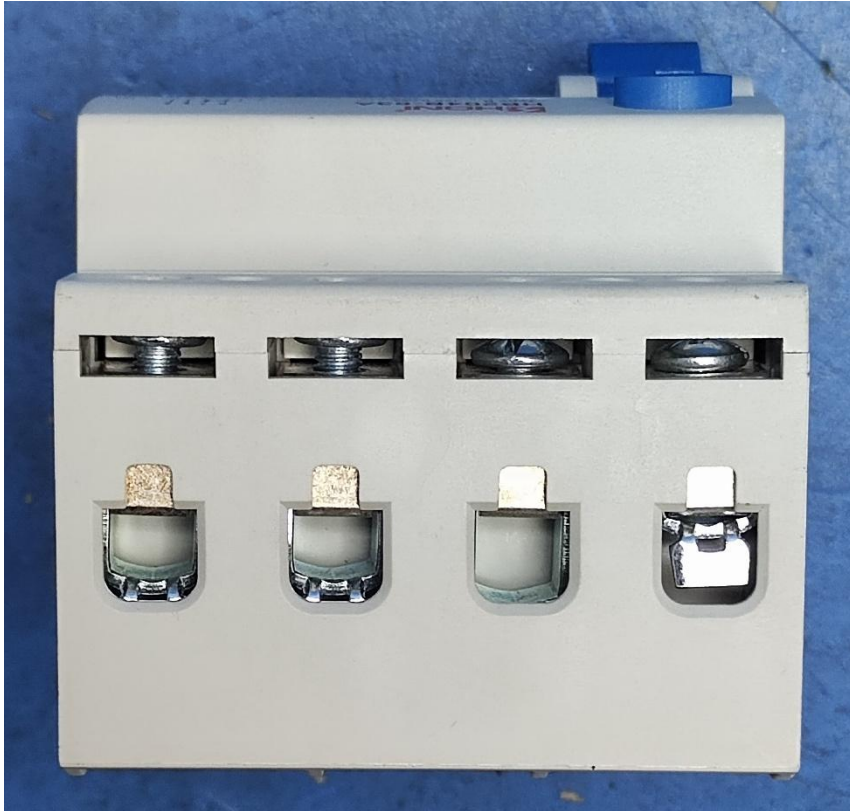

Photos of sample: 3P+N

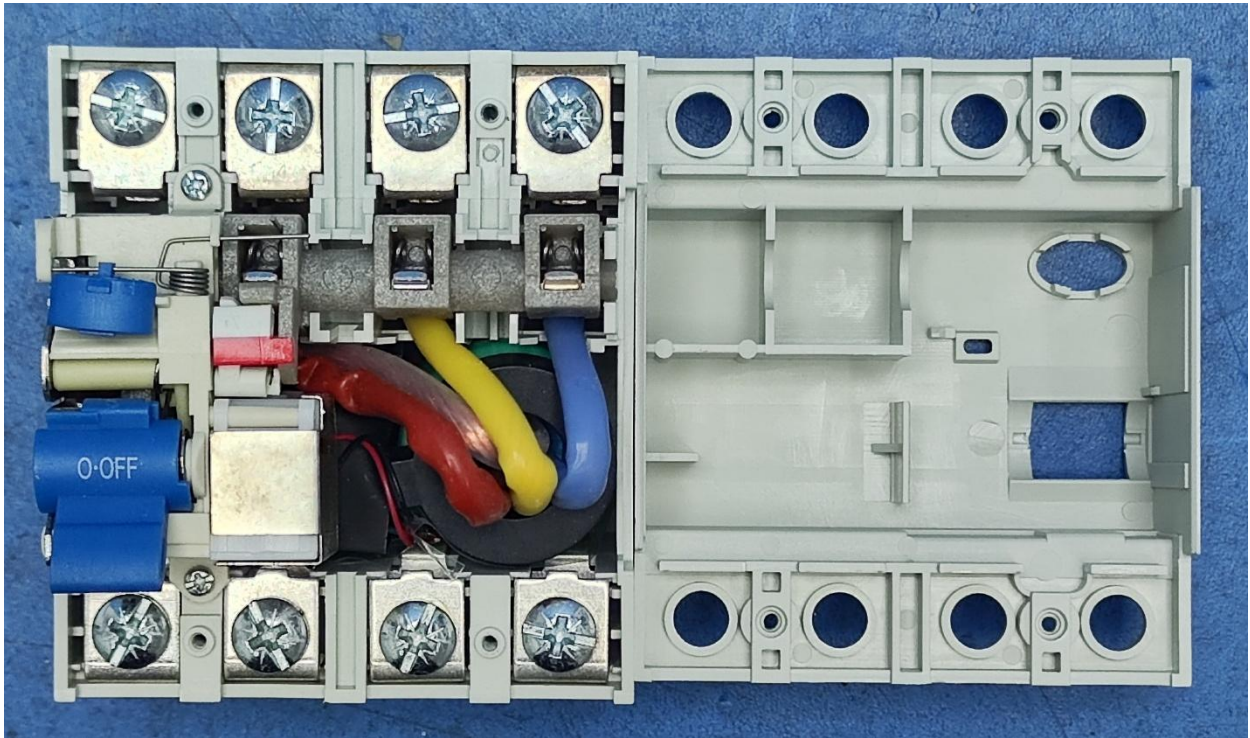

Photos of sample: 3P+N

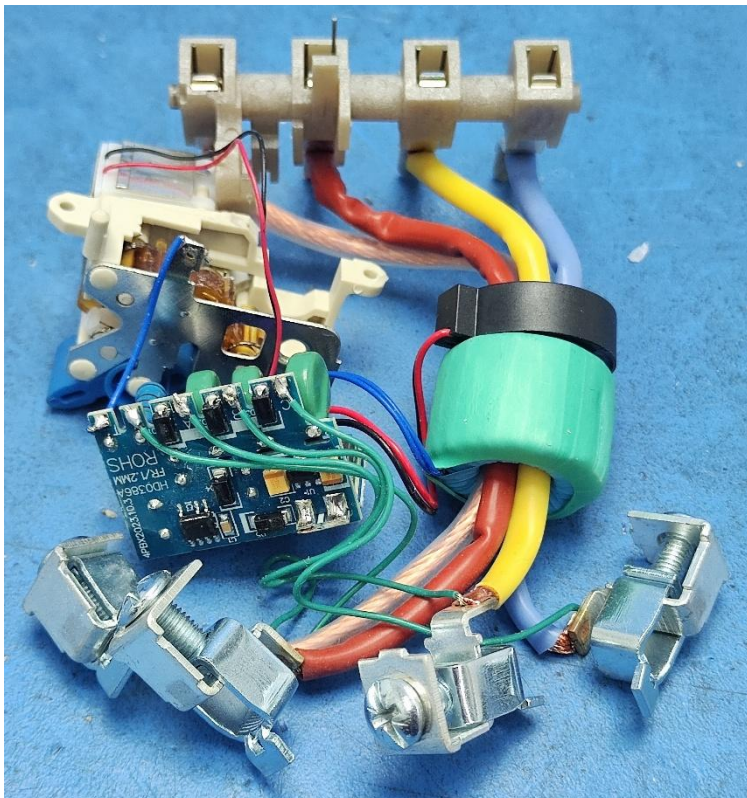
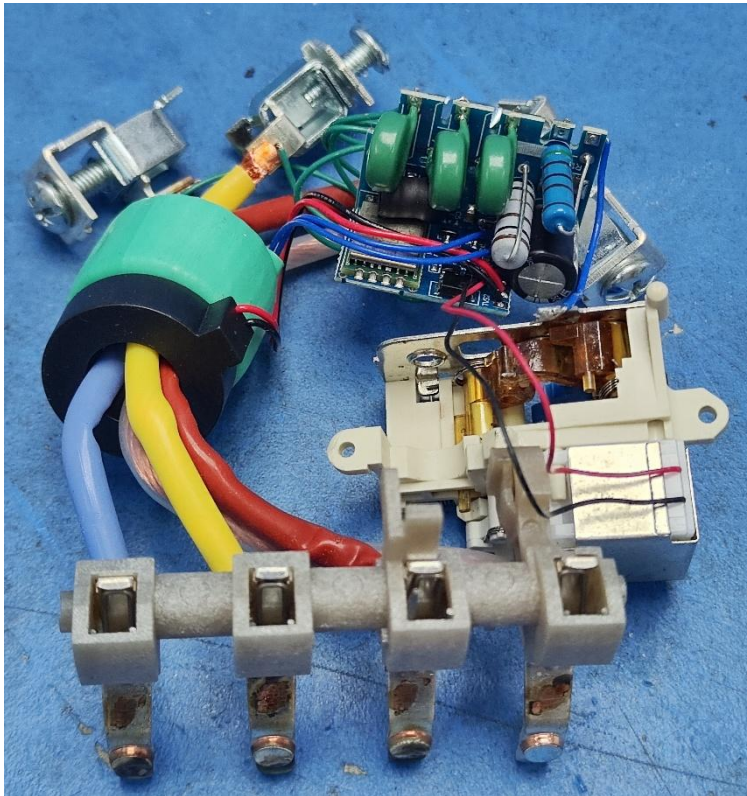

END of the report